

SYMBOLS

The packaging material, the type plate on the instrument and the manual may contain the following symbols or abbreviations:



Manufactured by:



This product fulfills the requirements of Regulation (EU) 2017/746 on in vitro diagnostic medical devices.



In vitro diagnostic medical device



Caution (refer to accompanying documents)!
Please refer to safety-related notes in the manual accompanying this device.



Please consult instructions for use



Symbol for the marking of important information for appropriate handling of the device



Biohazard
Samples containing material of human origin must be treated as potentially infectious. The relevant laboratory guidelines on safe use must be observed.



Symbol for the marking of electrical and electronics devices according to § 7 ElektroG

IP XO

No special protection against penetrating moisture (IP = International Protection)

REF

Order number

SN

Serial number

INSTRUMENT APPROVALS

The Photometer 680 meets the requirements of Regulation (EU) 2017/746 on in vitro diagnostic medical devices (IVDR). Furthermore, the Photometer 680 is manufactured according to the special safety requirements for IVD medical devices stated in EN 61010.

SAFETY INFORMATION

Operator qualification

Only appropriately trained operators are qualified to operate the device.

The risk of erroneous information due to measurement errors, which leads to an incorrect diagnosis and/or the failure of a reliable therapy, must be minimized as far as possible through regular quality controls.

Environmental conditions

The Photometer 680 is approved for indoor use only.
For further environmental conditions see chapter 10.1.

Patient ambience

The Photometer 680 may not be used in the patient ambience.



Electrical Safety

This device was examined and left the factory in perfect technical condition. To preserve this and protect safe and faultless operation, the operator must follow the orders and remarks of this operating manual.

Connect the device to grounded power outlets only. All peripheral devices that are connected to the Photometer 680 must comply with safety standard EN 62368-1. Before connecting read the documentation of the peripheral devices.

Opening covers or removing parts of the instrument, except where this can be achieved manually without the use of any tool, may expose voltage-carrying components. Connectors can be live, too. Never try to maintain or repair an open instrument which is carrying voltage.

Repairs at the device including replacement of the Lithium battery may be carried out only by authorized specialist staff. Through improper repairs the warranty extinguishes, and the operator can be heavily jeopardized.

If suspected the device can no longer be operated safely, turn it off and take steps to ensure that no one will subsequently attempt to use it.

Electromagnetic waves

Devices that emit electromagnetic waves may affect measured data, or cause the Photometer 680 to malfunction. Do not operate the following devices in the same room where the Photometer 680 is installed: mobile phone, transceiver, cordless phone, and other electrical devices that generate electromagnetic waves.



Reagents

Regarding reagents follow the safety as well as the operating instructions of the manufacturers.
Pay attention to the currently valid German "Gefahrstoffverordnung" (GefStoffV)!



Biological safety

Liquid waste is potentially biologically hazardous. Always wear gloves if handling those materials. Do not touch parts of the device other than those specified. Consult the laboratory protocol for handling biohazardous materials. Pay attention to the currently valid German "Biostoffverordnung" (BioStoffV)!



Spillings and cleaning

If a sample is spilled on the device, wipe up immediately and apply disinfectant.



Waste

Handle liquid waste properly, according to legislation on water pollution, and on the treatment of drainage and waste matter.

MANUFACTURER'S WARRANTY

ROBERT RIELE GmbH & Co KG warrants Photometer 680 against defects in material and workmanship. For further information contact the local distributor.

Any serious incident that has occurred in relation to the device shall be reported to the manufacturer and the competent authority of the Member State in which the user and/or the patient is established.

WASTE MANAGEMENT NOTE

At the end of the life or utilization time the device and the accessories can be given back to the manufacturer with costs for an environmental waste disposal. The previous professional decontamination has to be proved with a certificate.

Address of the manufacturer:



ROBERT RIELE GmbH & Co KG
Kurfuerstenstrasse 75-79
13467 BERLIN
GERMANY

Phone: +49 (0)30 404 40 87

Fax: +49 (0)30 404 05 29

E-mail: info@riele.de
www.riele.de

QUALITY MANAGEMENT SYSTEM

ROBERT RIELE GmbH & Co KG maintains a quality management system according to ISO 13485, certified by mdc medical device certification GmbH.

CONTENTS

| | | |
|----------|---|-----------|
| 1 | INTRODUCTION TO PHOTOMETER 680 | 7 |
| 2 | INSTALLATION | 8 |
| 2.1 | DELIVERY | 8 |
| 2.2 | PREPARATION FOR INSTALLATION | 8 |
| 2.3 | INSTALLATION | 8 |
| 3 | OPERATING ELEMENTS | 10 |
| 3.1 | FRONT | 10 |
| 3.2 | BACK | 10 |
| 3.3 | TOUCHSCREEN | 11 |
| 3.4 | CUVETTES AND CUVETTE ADAPTOR | 11 |
| 3.5 | OPTICAL FILTERS | 11 |
| 4 | PROGRAM SELECTION | 12 |
| 4.1 | Measurement with programmed methods | 12 |
| 4.2 | Measurement with basic methods | 13 |
| 4.3 | Method editor | 13 |
| 4.4 | Utility programs | 14 |
| 5 | CALCULATION PROCEDURES | 15 |
| 5.1 | GENERAL NOTES | 15 |
| 5.1.1 | Fundamental to the handling | 15 |
| 5.1.2 | Fundamental to the inputs | 15 |
| 5.1.3 | Fundamental to the methods with standard | 16 |
| 5.1.4 | Fundamental to the methods with multi-standards | 16 |
| 5.1.5 | Fundamental to the methods with reagent blank | 17 |
| 5.1.6 | Fundamental to ID-NO. and sample numerator | 17 |
| 5.1.7 | Fundamental to storing test results | 17 |
| 5.2 | ABBREVIATIONS | 18 |
| 5.3 | SURVEY OF THE METHODS | 19 |
| 5.4 | DESCRIPTION OF METHOD PROCEDURES | 20 |
| 5.4.1 | Calculation procedure 1 (C/F) | 21 |
| 5.4.2 | Calculation procedure 2 (C/F/Rb) | 22 |
| 5.4.3 | Calculation procedure 3 (C/F/Sb) | 23 |
| 5.4.4 | Calculation procedure 4 (C/F/SbRb) | 24 |
| 5.4.5 | Calculation procedure 5 (C/S) | 25 |
| 5.4.6 | Calculation procedure 6 (C/S/Rb) | 26 |
| 5.4.7 | Calculation procedure 7 (C/S/Sb) | 27 |
| 5.4.8 | Calculation procedure 8 (C/S/SbRb) | 28 |
| 5.4.9 | Calculation procedure 9 (FTK/F/Rb) | 29 |
| 5.4.10 | Calculation procedure 10 (FTK/S/Rb) | 30 |
| 5.4.13 | Calculation procedure 13 (TRANSMISSION) | 31 |
| 5.4.14 | Calculation procedure 14 (C/F Delta) | 32 |
| 5.4.15 | Calculation Procedure 16 (DELTA R1R2) | 34 |
| 6 | METHOD EDITOR | 36 |

| | | |
|-----------|---|-----------|
| 7 | UTILITY PROGRAMS | 39 |
| 7.1 | SELECTION OF UTILITY PROGRAMS..... | 39 |
| 7.2 | DESCRIPTION OF UTILITY PROGRAMS..... | 40 |
| 7.2.1 | Optic adjustment..... | 40 |
| 7.2.2 | Multi-standard functions..... | 40 |
| 7.2.3 | Printer ON / OFF..... | 42 |
| 7.2.4 | Set wavelength | 42 |
| 7.2.5 | Menu serial COM..... | 43 |
| 7.2.6 | Quality control..... | 44 |
| 7.2.7 | Settings printout..... | 48 |
| 7.2.8 | Stored results..... | 48 |
| 7.2.9 | Laboratory name..... | 49 |
| 7.2.10 | User name | 49 |
| 7.2.11 | Error list | 50 |
| 7.2.12 | Key signal ON / OFF..... | 50 |
| 7.2.13 | Touchscreen adjustment..... | 50 |
| 7.2.14 | Date / Time | 51 |
| 7.2.15 | Language..... | 52 |
| 7.2.16 | ADC counts (Optic)..... | 52 |
| 7.2.17 | Bar Code..... | 52 |
| 7.2.18 | Service tools | 53 |
| 8 | MAINTENANCE | 54 |
| 8.1 | CLEANING INSTRUCTION | 54 |
| 8.2 | CALIBRATING MEASURING SYSTEM..... | 54 |
| 9 | ERROR MESSAGE / CORRECTION | 55 |
| 9.1 | GENERAL NOTE | 55 |
| 9.2 | ACOUSTIC ERROR MESSAGES..... | 55 |
| 9.3 | PLAINTEXT ERROR MESSAGES..... | 55 |
| 9.4 | CODED ERROR MESSAGES | 55 |
| 10 | TECHNICAL DATA | 57 |
| 10.1 | ENVIRONMENTAL CONDITIONS..... | 57 |
| 10.2 | MINIMAL OPERATION QUALITY..... | 57 |
| 10.3 | TYPE PLATE | 57 |
| 10.4 | SHORT SPECIFICATIONS..... | 58 |
| 10.5 | TECHNICAL SPECIFICATIONS | 59 |
| 11 | ACCESSORIES AND SPARE PARTS..... | 61 |
| 12 | METHOD LIST | 62 |
| 12.1 | BASIC METHODS..... | 62 |
| 12.2 | LIST OF USER SPECIFIC METHODS | 63 |

1 INTRODUCTION TO PHOTOMETER 680

Intended Purpose:

This device is a manual clinical chemistry analyzer used to quantitatively determine clinical chemistry analytes in human serum, plasma and other clinical specimen from patients of all ages and independent of gender. The chemistry analyzer is used in combination with in vitro diagnostic reagents designed for manual procedures to be used by qualified laboratory technicians. Quality control is performed with clinical chemistry standards, calibrators and controls available from the respective manufacturer of reagents.

It is operated via touchscreen. Remote control is possible by a serial data interface (chapter 7.2.5 - Menu serial COM – REMOTE CONTROL).

The device is useable e.g. for wet clinical-chemical analyses. The solution can be measured in glass or disposable cuvettes placing one after the other.

For measuring methods several programmed methods with open parameters are available (chapter 5 - CALCULATION PROCEDURES and chapter 12 - METHOD LIST).

Besides, up to 231 methods - built up on the basic methods - can be established and stored by the operator with a method editor. A list of methods can be printed out (chapter 6 - METHOD EDITOR).

Up to 50 nonlinear calibration curves with maximum 20 sets of points can be stored (chapter 7.2.2 - Multi-standard functions).

The measuring wavelength is selected via pluggable optical filters. Filters with any wavelengths within the range are available as accessories.

The measuring data can be stored and managed in the Photometer 680 (chapter 7.2.8 - Stored results).

According to a GLP conformal documentation the names of lab and operator can be printed out as well as transferred to EDP (chapter 7.2.5 - Menu serial COM – EDP ON/OFF).

In Photometer 680 up to 50 methods can be supervised with a quality control (chapter 7.2.6 - Quality control).

Numerous utility programs permit the individual configuration of the device. Function tests support the analysis of sources of error.

Photometer 680 is future-proof by FLASH MEMORY technology: The operating system can be updated with program novelties and/or improvements comfortably, without having to open the equipment (chapter 7.2.5 - Menu serial COM – DOWNLOAD).

2 INSTALLATION

2.1 DELIVERY

Check the device and contents of the enclosed box as follows on visible transport damages and completeness:

- Photometer 680
- Power supply unit with power cord
- Operating Instructions



Inform the sales office immediately about transport damages. Keep the original packaging for a possible return.

2.2 PREPARATION FOR INSTALLATION

Place the device on a stable, level surface.

If the device was exposed to extraordinary fluctuation in temperature and/or humidity, it must acclimatize sufficiently before operation.

2.3 INSTALLATION

Photometer 680 operates at a voltage of 12 V_{DC}. In combination with the power supply unit it works with line voltage between 100 V_{AC} and 240 V_{AC} at 50/60 Hz. In addition, the device can be powered by an alternative voltage source such as battery, solar panel, vehicle electrical system, etc.



While connecting or disconnecting an external device (PC, printer) to Photometer 680 both devices must be switched off.

Switch on Photometer 680 by the switch at the back.



Greeting screen:

After switching on copyright, website, type of device and version designation are displayed.

DD/MM/YYYY – Release date of software

version (day, month, year)



Indication for the direction of the light.

[DELETE] Window will not be displayed next time.

(Appears again when overwriting the software, optic adjustment or when initializing the system.)

[OK] Exit the window. Window appears again next time you turn the device on.

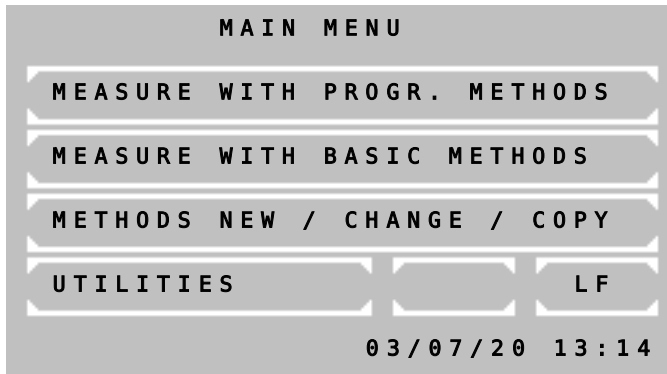

After around 15 minutes the device is stabilized and ready for measurement.

If errors appeared during operation, first of all they have to be confirmed with [E] before remedy (chapter 9 - ERROR MESSAGE / CORRECTION).

3 OPERATING ELEMENTS

3.1 FRONT

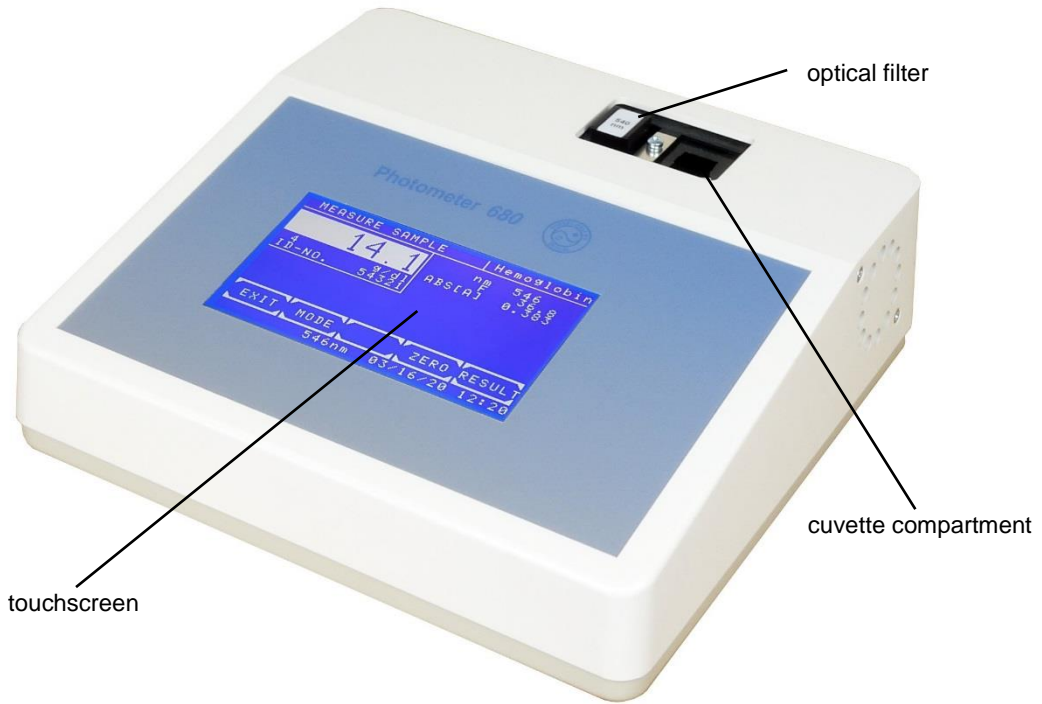

3.2 BACK

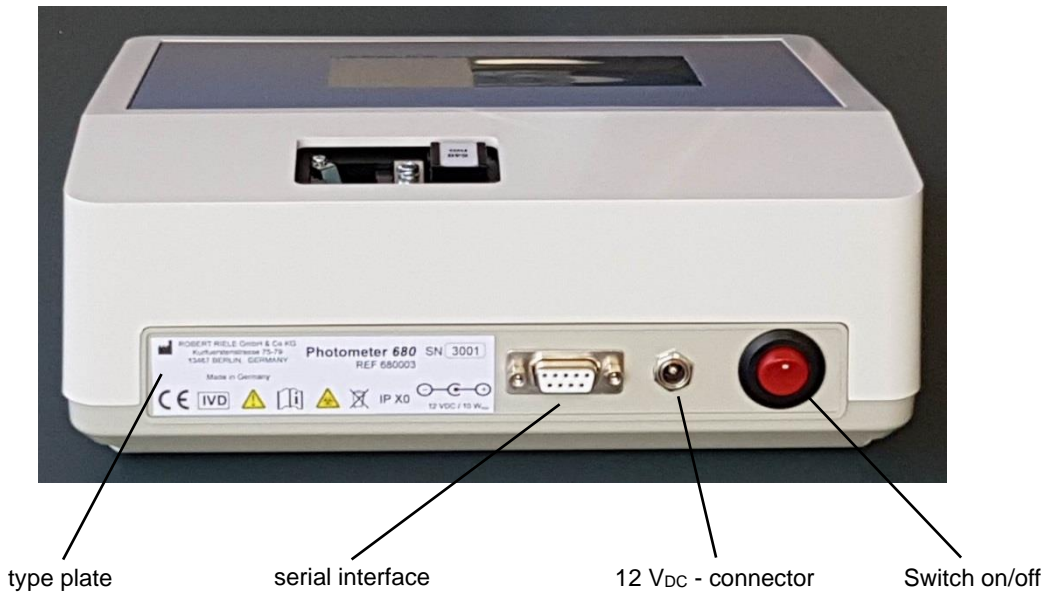

3.3 TOUCHSCREEN



The touchscreen shows applications and information. It is contact-sensitive and reacts to the pressure exerted on it. In order to execute a function, the desired range on the screen must be touched



The surface of the touchscreen may be never touched with ball-point pen, pencil or another pointed article!

3.4 CUVETTES AND CUVETTE ADAPTOR



The optical path is directed from the right to the left of the device. Insert single cuvette according to the drawing **OPTIC CONSTRUCTION** in TECHNICAL DATA.



Trigger setting to zero by [ZERO].

Trigger a normal measuring by [RESULT].

3.5 OPTICAL FILTERS

The wavelength is given by an optical filter in a holder put into the filter compartment. The nominal wavelength is printed on the holder (e. g. 546 nm as shown above).

Filters at hand can be declared within the utility programs (chapter 7.2.4 - Set wavelength).

Only declared wavelengths can be used in basic methods (chapter 4.2 - Measurement with basic methods) or in pre-programmed methods (chapter 4.1 - Measurement with programmed methods).

4 PROGRAM SELECTION

After switch-on the touchscreen shows the main menu.

From this screen the basic methods (unalterably programmed in the system) or operator specific programmed methods can be reached. Also the adjusting programs are started from this mask. With the method editor own methods can be established and changed. The utility programs cover the configuration adjustments and check routines.

After completion of a method or execution of a utility program the program always returns to the main menu.

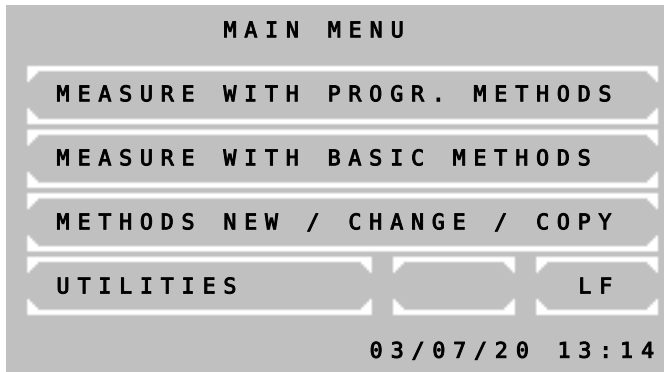

Main menu:

Down in the status line from left to right following is shown:

- Date in the format day/month/year
- Time

4.1 Measurement with programmed methods

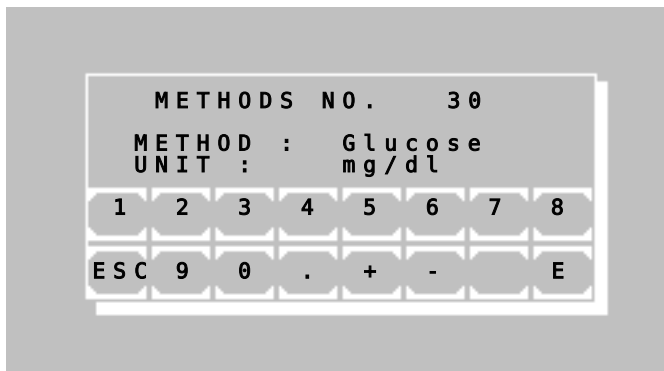

A programmed method for a photometric test can be called directly by input of the method number.

The valid range for a method number lies between 20 and 250.

Scroll all existing methods by [+] or [-]. If no method is programmed, a plain text error message (chapter 9.3 - PLAINTEXT ERROR MESSAGES) is shown.

Call the selected method by [E].
Return to main menu by [ESC].



A programmed method can be established via menu METHOD NEW /CHANGE / COPY (chapter 4.3 - Method editor). The transmission of a method collection is possible by PC with special software.

Further information:

Application sheets of reagent manufacturers

4.2 Measurement with basic methods

A photometric test can be executed by a method already permanently programmed, but open in all setting parameters. 15 different methods with different calculation procedures are available. Each of these methods can serve as prototype for a method programmed by the operator.

| BASIC METHODS | | PAGE 1 / 4 |
|-----------------------|--|------------|
| CONC. W. FACTOR | | PAGE |
| CONC. W. FACTOR RB | | |
| CONC. W. FACTOR SB | | |
| CONC. W. FACTOR RB SB | | EXIT |
| 03 / 07 / 20 | | 13 : 14 |

Available are:

- Absorbance measurement
- Concentration measurement / end point measurement
- Fixed time kinetic / two point kinetic
- Transmission

Scrolling through all methods is possible by [PAGE]. The current page is shown at the right upper screen corner. By [END] the program returns to the main menu.

A method is selected by pressing the corresponding key.

The following abbreviations are used for the distinction of the methods:

- CONC. = concentration
- F = factor
- STD = standard
- RB = reagent blank
- SB = sample blank

Further information:
Chapter: 5 - CALCULATION PROCEDURES

4.3 Method editor

| METHOD NEW / CHANGE / COPY | |
|----------------------------|------|
| METHOD COPY | LIST |
| METHOD EDIT | |
| METHOD NEW | |
| METHOD DELETE | EXIT |
| 03 / 07 / 20 13 : 14 | |

Each photometric test can be permanently stored with its setting parameters by the method editor.

With the functions of the method editor are possible the new installation, the change and removing a method.

By [LIST] an overview of the programmed methods can be printed and transmitted via the serial interface.

Further information:
Chapter: 6 - METHOD EDITOR

4.4 Utility programs

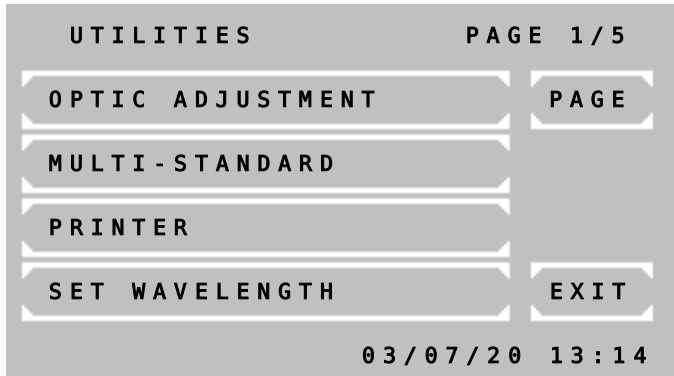

Utility programs are necessary for the adjustment and maintenance of Photometers 680.

Further information:
Chapter: 7 - UTILITY PROGRAMS

5 CALCULATION PROCEDURES

5.1 GENERAL NOTES

The device offers operator guidance in the display by a combination of plaintext and short terms.

Messages and inputs regarding the method always have to be confirmed by [OK]. By [EXIT] all methods can be broken off. For a restart see chapter 4 - PROGRAM SELECTION. Measuring is generally triggered by [RESULT], zero measuring by [ZERO].

5.1.1 Fundamental to the handling ...

-  Deviations from normal operation, caused by the device or by the operator, are notified by "ERROR". They always have to be confirmed by [E] (chapter 9 - ERROR MESSAGE / CORRECTION).

Example: The reading exceeds the programmed upper limit.

5.1.2 Fundamental to the inputs ...

- The input format of the factor and/or the standard with sign determines the output format of the result concerning the number of decimal places.
Example: With factor "36.8" the calculated concentration will be shown with one decimal place.
- Each factor or standard can be minus signed, so that the result is calculated with correct sign.
Example: The test GOT is programmed with the factor "-1746" because the measuring principle implies a decreasing absorbance.
- If for the factor or standard a "zero" is pre-programmed, during operation the user is asked to type in the actual value. Here, the input format of the "zero", e.g. "0" or "=0.0" determines the output. The old standard/factor of a previous measurement can be reused for further ones.
- For a homogeneous solution the input of a delay before a measuring is possible at all methods.
- All delay times can be cancelled by pressing the aspiration tube [P] for a long time.

5.1.3 Fundamental to the methods with standard ...

- Each measuring of a standard (calibrator) can be executed as single, double or triple determination. Following is shown:

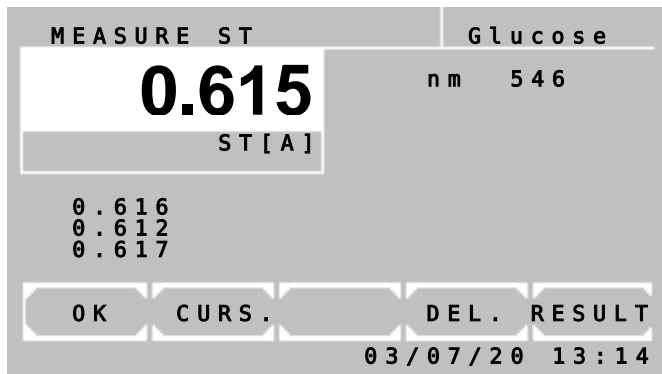

In the white reading window the averaged absorbance of the standard is shown.

Below the white reading window the absorbance 1, 2 and 3 of a standard are shown.

By [OK] the average of all values is taken over. Values with 0 are ignored and excluded from the calculation. The resulting factor is calculated from the average of the standard.

By [CURS.] a value is selected. A flashing white square marks the current value.

By [DEL.] a value is deleted and excluded from the calculation.

By [RESULT] a measuring is triggered.

- The determined resulting factor of a standard measurement is stored together with the corresponding method number. After renewed selection of this method the last resulting factor is offered as "OLD STD".
- The principle of the multiple measurement can also be expanded to all measurements. The corresponding entry can be set invoking a basic method. The parameter is definable in preprogrammed methods (chapter 6 - METHOD EDITOR).

5.1.4 Fundamental to the methods with multi-standards ...

- Linear calibration is used in the case of two calibrators. The absorbance forms a linear diagram with the concentrations (chapter 7.2.2 - Multi-standard functions).
- Nonlinear calibration is used for samples with a nonlinear but reproducible connection between the absorbance and the concentrations. At least three (maximum 20) calibrators are required for nonlinear calibration (chapter 7.2.2 - Multi-standard functions).

5.1.5 Fundamental to the methods with reagent blank...

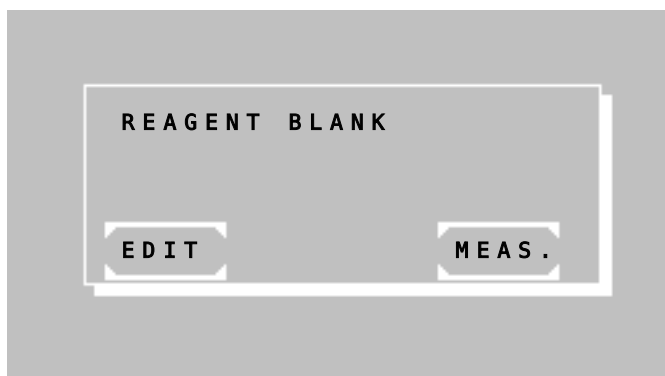

After selecting a method with reagent blank (RB), the reagent blank can be measured, entered or put on zero.

Press [EDIT] to enter the RB manually or [MEAS.] to measure it.



When using a programmed method based on a calculation procedure with RB, the used RB will be stored together with the corresponding method number.

After renewed selection of this method the last stored reagent blank is offered as "OLD RB".

Press [YES] to use the last stored RB or [NO] to enter or measure it.

5.1.6 Fundamental to ID-NO. and sample numerator...

- All test results are labeled with a numerator.
- Additionally, all results can be labeled with a 5-digit ID-NO. When the ID-NO. is not zero it will be displayed and printed together with the sample result.
- When a method is selected you can edit both numerator and ID-NO. of a sample with [MODE] [NUM.]

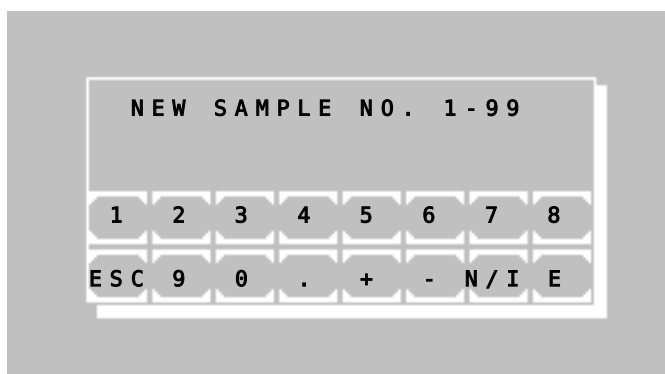

Press [N / I] to switch between editing numerator and ID-NO.

5.1.7 Fundamental to storing test results...

- All test results are stored automatically. Up to 1000 results can be stored in memory.
- See table 7.2.4.1 for the format of the stored data.
- Stored results can be output through serial interface (chapter 7.2.8 - Stored results).
- When memory is full oldest test results will be overwritten or you can send all results through the serial interface and then delete them.

5.2 ABBREVIATIONS

| | |
|-------------------|---|
| A, ABS | Absorbance |
| A _{RB} | Absorbance of reagent blank |
| A _{RB,0} | At Fixed Time: absorbance of reagent blank after incubation time T ₀ |
| A _{RB,1} | At Fixed Time: absorbance of reagent blank after reaction time T ₁ |
| A _S | Absorbance of sample |
| A _{S,0} | At Fixed Time: absorbance of sample after incubation time T ₀ |
| A _{S,1} | At Fixed Time: absorbance of sample after reaction time T ₁ |
| A _{SB} | Absorbance of sample blank |
| A _{ST} | Absorbance of standard |
| A _{ST,0} | At Fixed Time: absorbance of standard after incubation time T ₀ |
| A _{ST,1} | At Fixed Time: absorbance of standard after reaction time T ₁ |
| A _{STB} | Absorbance of standard blank |
| C | Concentration |
| C _{ST} | Concentration of standard |
| CV | Quality control: Coefficient of variation |
| F | Factor |
| FTK | Fixed Time Kinetic |
| n | Quality control: number of values |
| nm | Nanometer (dimension of wavelength) |
| m | Quality control: mean of values |
| R | Result, Sample |
| R _b | Reagent blank |
| S, ST | Standard |
| ST _b | Standard blank |
| S _b | Sample blank |
| s | Quality control: standard deviation |
| TRANSM., T | Transmission in % |
| T ₀ | At Fixed Time: incubation time in seconds |
| T ₁ | At Fixed Time: reaction time in seconds |

5.3 SURVEY OF THE METHODS

The calculation procedures, on which all methods are traceable from the list of methods, are mentioned in the following table. Criterion is the characteristic of the calculation procedure (see below). For detailed description of the respectively accompanying procedure of method see chapter 5.4 - DESCRIPTION OF METHOD PROCEDURES.

| CP-No. | Characteristic | Method | Calculation formula |
|--------|----------------|-----------------------------------|---|
| CP 1 | C/F | Endpoint with Factor | $C = F * A_S$ |
| CP 2 | C/F/Rb | Endpoint with Factor | $C = F * (A_S - A_{RB})$ |
| CP 3 | C/F/Sb | Endpoint with Factor | $C = F * A_S - A_{SB} $ |
| CP 4 | C/F/SbRb | Endpoint with Factor | $C = F * (A_S - A_{SB} - A_{RB})$ |
| CP 5 | C/S | Endpoint with Standard | $C = F * A_S$ |
| CP 6 | C/S/Rb | Endpoint with Standard | $C = F * (A_S - A_{RB})$ |
| CP 7 | C/S/Sb | Endpoint with Standard | $C = F * A_S - A_{SB} $ |
| CP 8 | C/S/SbRb | Endpoint with Standard | $C = F * (A_S - A_{SB} - A_{RB})$ |
| CP 9 | FTK/F/Rb | Fixed Time Kinetic with Factor | $C = F * (A_{S,0} - A_{S,1} - A_{RB,0} - A_{RB,1})$ |
| CP 10 | FTK/S/Rb | Fixed Time Kinetic with Standard | $C = F * (A_{S,0} - A_{S,1} - A_{RB,0} - A_{RB,1})$ |
| CP 11 | KIN/F/Rb | Kinetic with Factor | $C = F * (\Delta A_{S,Minit} - \Delta A_{RB,Minit})$ |
| CP 12 | KIN/S/Rb | Kinetic with Standard | $C = F * (\Delta A_{S,Minit} - \Delta A_{RB,Minit})$ |
| CP 13 | TRANSM. | Transmission in % | |
| CP 14 | C/F DELTA | Endpoint with Factor | $C = F * (\Delta A_{S2-Sb2} - \Delta A_{S1-Sb1})$ |
| CP 16 | DELTA R1R2 | Diff. measurement of two reagents | $C = \Delta A_S$ |

Explanations:

CP-No.Number of the calculation procedure (chapter 6 - METHOD EDITOR)

CharacteristicName of the calculation procedure (chapter 12.1 - BASIC METHOD)

Calculation formulaCalculation basis of basic method

5.4 DESCRIPTION OF METHOD PROCEDURES

In the descriptions of the calculation procedures a typical print-out by the internal printer is shown on the left side.

All print-outs begin with the device information, laboratory data and method parameters followed by all measuring data necessary for a manual examination of the readings.

The measuring window

The arrangement of the measuring window is alike in all calculation procedures. Depending on the method, various numbers of readings or diagrams are shown.

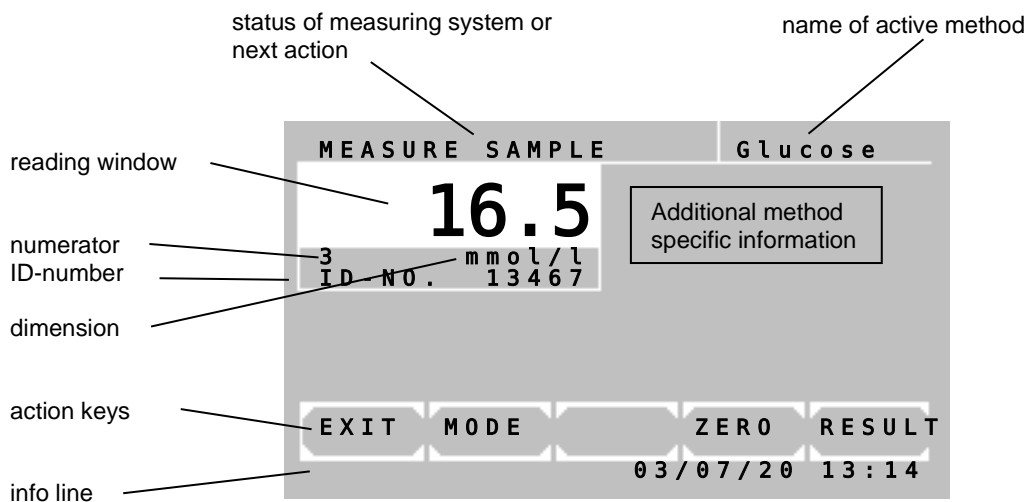

Functions of the action keys in the measuring window:

[EXIT] Leads to the query whether the measuring program is to be terminated

[MODE] Occupies the action keys with following mode functions:

| | | | | |
|--------|--------|------|---------|----------|
| [NUM.] | [MODE] | [LF] | [QC] | [RETURN] |
| [PRN] | [INFO] | | [M-STD] | [RETURN] |

[ZERO] Starts the zero measuring

[RESULT] Starts the measuring

Mode functions:

[NUM.] Edit sample numerator or ID-NO. (chapter 5.1.6)

[QC] Quality Control functions

[PRN] Switch printer on / off

[INFO] Display/printout of detailed results on kinetic measurement

[M-STD] Multi standard functions

[RETURN] Return to normal functions

5.4.1 Calculation procedure 1 (C/F)

Method at which a measured sample value A_S is multiplied with a predefined factor F.

Calculation procedureCP 1
 Characteristic C / F
 MethodEnd Point with Factor
 Calculation formula $C = F * A_S$
 Factor given / entering

| | |
|---|--|
| <pre> PHOTOMETER 680 # 3000 V7.Xa dd/mm/yy D LAB.: RIELE BERLIN USER 1: M.MUSTERMANN DATE: 03/18/20 TIME: 08:44:12 METHOD 20: HEMOGLOBIN PROGRAM: 1 FACTOR: 29.4 WAVELENGTH: 405nm DELAY: 5s MAX.UNITS: 25 UNIT: g/l - - - - - MEASURE ZERO NO. ABS. RESULT 1 0.675 19.8 ID-NO. 5 2 0.843 24.8 ID-NO. 5 </pre> | <p>Start method selection in the main menu. See chapter: 4.1 - Measurement with programmed methods 4.2 - Measurement with basic methods</p> <p>In the case of activated printer the print-out of the method data follows.</p> <p>The measuring window is shown.</p> <p>Method procedure: →Insert / measure zero solution</p> <p>→Insert / measure sample</p> <p>→Insert / measure sample</p> |
|---|--|

5.4.2 Calculation procedure 2 (C/F/Rb)

Method at which the difference of sample value A_S and reagent blank A_{RB} is multiplied with a given factor F . The reagent blank A_{RB} is entered or measured once.

Calculation procedureCP 2
 Characteristic C / F / Rb
 MethodEnd Point with Factor
 Calculation formula $C = F * (A_S - A_{RB})$
 Factor given / entering
 Reagent blankentering or measuring

| | |
|--|--|
| PHOTOMETER 680 # 3000 V7.Xa dd/mm/yy D LAB.: RIELE BERLIN USER 1: M.MUSTERMANN DATE: 03/18/20 TIME: 08:44:12 METHOD 21: HDL - C PROGRAM: 2 FACTOR: 325 WAVELENGTH: 546nm DELAY: 5s UNIT: mg/dl ----- MEASURE ZERO Rb[A]: 0.058 NO. ABS. RESULT 1 1.064 327 ID-NO. 5 2 1.188 367 ID-NO. 5 3 1.340 417 ID-NO. 5 | Start method selection in the main menu. See chapter: 4.1 - Measurement with programmed methods 4.2 - Measurement with basic methods In the case of activated printer the print-out of the method data follows. The measuring window is shown. Method procedure: →Insert / measure zero solution →Insert / measure reagent blank →Insert / measure sample →Insert / measure sample →Insert / measure sample |
|--|--|

5.4.3 Calculation procedure 3 (C/F/Sb)

Method at which the difference of sample value A_S and sample blank A_{SB} regarding the amount is multiplied with a given factor F . The sample blank A_{SB} is measured before every test.

Calculation procedureCP 3
 Characteristic C / F / Sb
 MethodEnd Point with Factor
 Calculation formula $C = F * |A_S - A_{SB}|$
 Factor given / entering

| | |
|---|--|
| <pre> PHOTOMETER 680 # 3000 V7.Xa dd/mm/yy D LAB.: RIELE BERLIN USER 1: M.MUSTERMANN DATE: 03/18/20 TIME: 08:44:12 METHOD 23: BILIRUBIN PROGRAM: 3 FACTOR: 12.80 WAVELENGTH: 546nm DELAY: 5s MAX.UNITS: 8.0 UNIT: mg/dl - - - - - MEASURE ZERO NO. ABS. RESULT 1 1.000 4.21 ID-NO. 5 Sb[A]: 0.671 2 1.215 4.25 ID-NO. 5 Sb[A]: 0.884 3 1.033 4.23 ID-NO. 5 Sb[A]: 0.702 </pre> | <p>Start method selection in the main menu. See chapter: 4.1 - Measurement with programmed methods 4.2 - Measurement with basic methods</p> <p>In the case of activated printer the print-out of the method data follows.</p> <p>The measuring window is shown.</p> <p>Method procedure: →Insert / measure zero solution</p> <p>→Insert / measure sample blank →Insert / measure sample</p> <p>→Insert / measure sample blank →Insert / measure sample</p> <p>→Insert / measure sample blank →Insert / measure sample</p> |
|---|--|

5.4.4 Calculation procedure 4 (C/F/SbRb)

Method at which the reagent blank A_{RB} is subtracted of the difference of sample value A_S and sample blank A_{SB} regarding the amount, and this difference is multiplied with a given factor F .
 The sample blank A_{SB} is measured before every test. The reagent blank A_{RB} is entered or measured once.

Calculation procedureCP 4
 Characteristic C / F / SbRb
 MethodEnd Point with Factor
 Calculation formula $C = F * (|A_S - A_{SB}| - A_{RB})$
 Factor given / entering
 Reagent blankentering or measuring

| <p>PHOTOMETER 680 # 3000 V7.Xa dd/mm/yy D LAB.: RIELE BERLIN USER 1: M.MUSTERMANN DATE: 03/18/20 TIME: 08:44:12 METHOD 24: Fe PROGRAM: 4 FACTOR: 1330 WAVELENGTH: 578nm TEMPERATURE: 37C MEAS. VOLUME: 900ul WASH VOLUME: 1000ul DELAY: 5s MIN.UNITS: 37 MAX.UNITS: 158 UNIT: ug/dl</p> <hr/> <p>MEASURE ZERO</p> <p>Rb[A]: 0.085</p> <table border="1"> <thead> <tr> <th>NO.</th> <th>ABS.</th> <th>RESULT</th> </tr> </thead> <tbody> <tr> <td>1</td> <td>0.715</td> <td>154</td> </tr> <tr> <td></td> <td>Sb[A]:</td> <td>0.486</td> </tr> <tr> <td>2</td> <td>0.646</td> <td>49</td> </tr> <tr> <td></td> <td>Sb[A]:</td> <td>0.497</td> </tr> </tbody> </table> | NO. | ABS. | RESULT | 1 | 0.715 | 154 | | Sb[A]: | 0.486 | 2 | 0.646 | 49 | | Sb[A]: | 0.497 | <p>Start method selection in the main menu. See chapter: 4.1 - Measurement with programmed methods 4.2 - Measurement with basic methods</p> <p>In the case of activated printer the print-out of the method data follows.</p> <p>The measuring window is shown.</p> <p>Method procedure:</p> <p>→Insert / measure zero solution</p> <p>→Insert / measure reagent blank</p> <p>→Insert / measure sample blank →Insert / measure sample</p> <p>→Insert / measure sample blank →Insert / measure sample</p> |
|--|--------|--------|--------|---|-------|-----|--|--------|-------|---|-------|----|--|--------|-------|---|
| NO. | ABS. | RESULT | | | | | | | | | | | | | | |
| 1 | 0.715 | 154 | | | | | | | | | | | | | | |
| | Sb[A]: | 0.486 | | | | | | | | | | | | | | |
| 2 | 0.646 | 49 | | | | | | | | | | | | | | |
| | Sb[A]: | 0.497 | | | | | | | | | | | | | | |

5.4.5 Calculation procedure 5 (C/S)

Method at which a measured absorbance value A_S is multiplied with a factor F which is determined by measuring of a standard solution with known concentration C_{ST} .

Calculation procedureCP 5
 CharacteristicC / S
 Method End Point with Standard
 Calculation formula $C = F * A_S$
 Resulting factor $F = C_{ST} / A_{ST}$

| | |
|---|---|
| <p>PHOTOMETER 680 # 3000 V7.Xa dd/mm/yy D LAB.: RIELE BERLIN USER 1: M.MUSTERMANN DATE: 03/18/20 TIME: 08:44:12 METHOD 25: GLUCOSE PROGRAM: 5 STANDARD: 5.55 WAVELENGTH: 546nm DELAY: 3s MAX.UNITS: 22.2 UNIT: mmol/l ----- MEASURE ZERO ST[A] 1: 1.110 ST[A] 2: 1.093 ST[A] 3: 1.059 ST[A]: 1.088 FACTOR: 5.10 NO. ABS. RESULT 1 1.026 5.23 ID-NO. 5 2 1.357 6.92 ID-NO. 5 3 1.582 8.07</p> | <p>Start method selection in the main menu. See chapter: 4.1 - Measurement with programmed methods 4.2 - Measurement with basic methods In the case of activated printer the print-out of the method data follows. The measuring window is shown. Method procedure: →Insert / measure zero solution →Insert / measure standard 1 →Insert / measure standard 2 (optional) →Insert / measure standard 3 (optional) (Averaged standard) (Resulting factor) →Insert / measure sample →Insert / measure sample →Insert / measure sample</p> |
|---|---|

5.4.6 Calculation procedure 6 (C/S/Rb)

Method at which the difference of sample value A_S and reagent blank A_{RB} is multiplied with a factor F which is determined by measuring of a standard solution with known concentration C_{ST} and under consideration of reagent blank A_{RB} .

The reagent blank A_{RB} is entered or measured once.

Calculation procedureCP 6
 Characteristic C / S / Rb
 Method End Point with Standard
 Calculation formula $C = F * (A_S - A_{RB})$
 Resulting factor $F = C_{ST} / (A_{ST} - A_{RB})$
 Reagent blank entering or measuring

| | |
|--|--|
| <pre> PHOTOMETER 680 # 3000 V7.Xa dd/mm/yy D LAB.: RIELE BERLIN USER 1: M.MUSTERMANN DATE: 03/18/20 TIME: 08:44:12 METHOD 26: SODIUM PROGRAM: 6 STANDARD: 150.0 WAVELENGTH: 405nm DELAY: 3s MAX.UNITS: 300 UNIT: mmol/l - - - - - MEASURE ZERO Rb[A]: 0.108 ST[A] 1: 1.112 ST[A] 2: 1.132 ST[A] 3: 1.118 ST[A]: 1.121 FACTOR: 148.2 NO. ABS. RESULT 1 1.449 198.7 ID-NO. 5 2 1.118 149.6 ID-NO. 5 5 2.006 281.2 </pre> | <p>Start method selection in the main menu. See chapter: 4.1 - Measurement with programmed methods 4.2 - Measurement with basic methods</p> <p>In the case of activated printer the print-out of the method data follows.</p> <p>The measuring window is shown.</p> <p>Method procedure: →Insert / measure zero solution →Insert / measure reagent blank →Insert / measure standard 1 →Insert / measure standard 2 (optional) →Insert / measure standard 3 (optional)</p> <p>(Averaged standard) (Resulting factor)</p> <p>→Insert / measure sample →Insert / measure sample →Insert / measure sample</p> |
|--|--|

5.4.7 Calculation procedure 7 (C/S/Sb)

Method at which the difference of sample value A_S and sample blank A_{SB} regarding the amount is multiplied with a factor F which is determined by measuring of a standard solution with known concentration C_{ST} and under consideration of standard blank A_{STB} .

The sample blank A_{SB} is measured before every test.

Calculation procedureCP 7
 Characteristic C / S / Sb
 Method End Point with Standard
 Calculation formula $C = F * |A_S - A_{SB}|$
 Resulting factor $F = C_{ST} / |A_{ST} - A_{STB}|$

| | |
|---|---|
| <pre> PHOTOMETER 680 # 3000 V7.Xa dd/mm/yy D LAB.: RIELE BERLIN USER 1: M.MUSTERMANN DATE: 03/18/20 TIME: 08:44:12 METHOD 27: UREA COL PROGRAM: 7 STANDARD: 50.0 WAVELENGTH: 546nm DELAY: 3s MAX.UNITS: 220 UNIT : mg/dl ----- MEASURE ZERO ST[A] 1: 0.614 ST[A] 2: 0.629 ST[A] 3: 0.620 ST[A]: 0.621 STb[A]: 0.106 DELTA ST: 0.515 FACTOR: 97.1 NO. ABS. RESULT 1 2.292 197.6 ID-NO. 5 Sb[A]: 0.257 2 2.340 198.0 ID-NO. 5 Sb[A]: 0.300 3 2.223 197.2 ID-NO. 5 Sb[A]: 0.193 </pre> | <p>Start method selection in the main menu. See chapter: 4.1 - Measurement with programmed methods 4.2 - Measurement with basic methods</p> <p>In the case of activated printer the print-out of the method data follows.</p> <p>The measuring window is shown.</p> <p>Method procedure: →Insert / measure zero solution</p> <p>→Insert / measure standard blank →Insert / measure standard 1 →Insert / measure standard 2 (optional) →Insert / measure standard 3 (optional) (Averaged standard) (standard blank) (Averaged standard minus standard blank) (Resulting factor)</p> <p>→Insert / measure sample blank →Insert / measure sample</p> <p>→Insert / measure sample blank →Insert / measure sample</p> <p>→Insert / measure sample blank →Insert / measure sample</p> |
|---|---|

5.4.8 Calculation procedure 8 (C/S/SbRb)

Method at which the reagent blank A_{RB} is subtracted of the difference of sample value A_S and sample blank A_{SB} regarding the amount and this difference is multiplied with a factor F which is determined by measuring of a standard solution with known concentration C_{ST} and under consideration of standard blank A_{STB} and the reagent blank A_{RB} .

The sample blank A_{SB} is measured before every test. The reagent blank A_{RB} is entered or measured once.

Calculation procedureCP 8
 CharacteristicC / S / SbRb
 Method End Point with Standard
 Calculation formula $C = F * (|A_S - A_{SB}| - A_{RB})$
 Resulting factor $F = C_{ST} / (|A_{ST} - A_{STB}| - A_{RB})$
 Reagent blank entering or measuring

| | |
|--|---|
| PHOTOMETER 680 # 3000 V7.Xa dd/mm/yy D LAB.: RIELE BERLIN USER 1: M.MUSTERMANN DATE: 03/18/20 TIME: 08:44:12 METHOD 28: Ca PROGRAM: 8 STANDARD: 8.02 WAVELENGTH: 546nm TEMPERATURE: 37C MEAS. VOLUME: 900uL WASH VOLUME: 1000uL DELAY: 3s MAX.UNITS: 12 UNIT: mg/dL - - - - - MEASURE ZERO Rb[A]: 0.150 ST[A] 1: 1.485 ST[A] 2: 1.521 ST[A] 3: 1.495 ST[A]: 1.501 STb[A]: 0.479 DELTA ST: 1.022 FACTOR: 8.74 NO. ABS. RESULT 1 1.495 7.89 Sb[A]: 0.489 2 1.542 7.89 Sb[A]: 0.535 3 1.394 8.39 Sb[A]: 0.329 | Start method selection in the main menu. See chapter: 4.1 - Measurement with programmed methods 4.2 - Measurement with basic methods In the case of activated printer the print-out of the method data follows. The measuring window is shown. Method procedure: →Insert / measure zero solution →Insert / measure reagent blank →Insert / measure standard blank →Insert / measure standard 1 →Insert / measure standard 2 (optional) →Insert / measure standard 3 (optional) (Averaged standard) (standard blank) (Averaged standard minus standard blank) (Resulting factor) →Insert / measure sample blank →Insert / measure sample →Insert / measure sample blank →Insert / measure sample →Insert / measure sample blank →Insert / measure sample |
|--|---|

5.4.9 Calculation procedure 9 (FTK/F/Rb)

Method at which a reagent blank is measured after an incubation time ($\Rightarrow A_{RB,0}$) and after a reaction time ($\Rightarrow A_{RB,1}$) and also a sample after an incubation time ($\Rightarrow A_{S,0}$) and after a reaction time ($\Rightarrow A_{S,1}$). The difference from the change of the test and the change of the reagent blank is multiplied by a predefined factor F. The reagent blank A_{RB} is entered or measured once.

During the procedure the dialog asks for the use of a reagent blank. The default value is OFF. To continue without reagent blank press [ENTER].

After each measurement the next sample can be measured with [NEXT].
With [RESULT] it is possible to measure the same sample again.

Calculation procedureCP 9
Characteristic FTK / F / Rb
Method Fixed Time with Factor
Calculation formula $C = F * (|A_{S,0} - A_{S,1}| - |A_{RB,0} - A_{RB,1}|)$
Factor given / entering
Reagent blank entering or measuring

| | |
|--|---|
| <pre> PHOTOMETER 680 # 3000 V7.Xa dd/mm/yy D LAB.: RIELE BERLIN USER 1: M.MUSTERMANN DATE: 03/18/20 TIME: 08:44:12 METHOD 29: CK-MB PROGRAM: 9 FACTOR: 2751.3 WAVELENGTH: 340nm INCUBATION: 120s REACTION: 180s MAX.UNITS: 1500 UNIT: U/l - - - - - MEASURE ZERO Rb[A]: 0.000 NO. ABS. RESULT 1 1.005 910.7 ID-NO. 5 DELTA [A]: 0.331 2 1.029 1128.1 ID-NO. 5 DELTA [A]: 0.410 3 0.829 1381.2 ID-NO. 5 DELTA [A]: 0.502 </pre> | <p>Start method selection in the main menu. See chapter: 4.1 - Measurement with programmed methods 4.2 - Measurement with basic methods</p> <p>In the case of activated printer the print-out of the method data follows.</p> <p>The measuring window is shown.</p> <p>Method procedure: → Insert / measure zero solution</p> <p>Without reagent blank (insert / measure optionally)</p> <p>→ Insert / measure sample</p> <p>→ Insert / measure sample</p> <p>→ Insert / measure sample</p> |
|--|---|

5.4.10 Calculation procedure 10 (FTK/S/Rb)

Method at which a reagent blank is measured after an incubation time ($\Rightarrow A_{RB,0}$) and after a reaction time ($\Rightarrow A_{RB,1}$) and also a sample after an incubation time ($\Rightarrow A_{S,0}$) and after a reaction time ($\Rightarrow A_{S,1}$). The difference from the change of the sample and the change of the reagent blank becomes multiplied with a factor F which is determined by means of the change of standard solution $|A_{ST,0}-A_{ST,1}|$ and the change of reagent blank $|A_{RB,0}-A_{RB,1}|$ during the reaction time and given concentration of standard. The reagent blank A_{RB} is entered or measured once.

During the procedure the dialog asks for the use of a reagent blank. The default value is OFF. To continue without reagent blank press [ENTER].

After each measurement the next sample can be measured with [NEXT]. With [RESULT] it is possible to measure the same sample again.

Calculation procedureCP 10
 Characteristic FTK / S / Rb
 Method Fixed Time with Standard
 Calculation formula $C = F * (|A_{S,0} - A_{S,1}| - |A_{RB,0} - A_{RB,1}|)$
 Resulting factor $F = C_{ST} / (|A_{ST,0}-A_{ST,1}| - |A_{RB,0}-A_{RB,1}|)$
 Reagent blankentering or measuring

| | |
|--|--|
| <p>PHOTOMETER 680 # 3000 V7.Xa dd/mm/yy D LAB.: RIELE BERLIN USER 1: M.MUSTERMANN DATE: 03/18/20 TIME: 08:44:12 METHOD 30: CREATININ PROGRAM: 10 STANDARD: 2.00 WAVELENGTH: 492nm INCUBATION: 45s REACTION: 60s MAX.UNITS: 25 UNIT: mg/dl</p> <p>----- MEASURE ZERO</p> <p>Rb[A]: 0.000</p> <p>ST/KIN 1: 0.194 ST/KIN 2: 0.203 ST/KIN 3: 0.214 ST/KIN: 0.204 FACTOR: 9.80</p> <p>NO. ABS. RESULT 1 0.326 9.84 ID-NO. 5 DELTA [A]: 1.005 2 0.336 10.81 ID-NO. 5 DELTA [A]: 1.103 3 0.329 12.84 ID-NO. 5 DELTA [A]: 1.310</p> | <p>Start method selection in the main menu. See chapter: 4.1 - Measurement with programmed methods 4.2 - Measurement with basic methods</p> <p>In the case of activated printer the print-out of the method data follows.</p> <p>The measuring window is shown.</p> <p>Method procedure: →Insert / measure zero solution</p> <p>Without reagent blank (insert / measure optionally)</p> <p>→Insert / measure standard 1 →Insert / measure standard 2 (optional) →Insert / measure standard 3 (optional) (Averaged standard) (Resulting factor)</p> <p>→Insert / measure sample</p> <p>→Insert / measure sample</p> <p>→Insert / measure sample</p> |
|--|--|

5.4.13 Calculation procedure 13 (TRANSMISSION)

Calculation procedureCP 13
 Characteristic T in %

| <p>PHOTOMETER 680 # 3000 V7.Xa dd/mm/yy D LAB.: RIELE BERLIN USER 1: M.MUSTERMANN DATE: 03/18/20 TIME: 08:44:12 METHOD 13: TRANSM. PROGRAM: 13 FACTOR: 1.0 WAVELENGTH: 546nm DELAY: 2s UNIT: %</p> <p>MEASURE 100%</p> <table border="1"> <thead> <tr> <th>NO.</th> <th>ABS.</th> <th>RESULT</th> </tr> </thead> <tbody> <tr> <td>1</td> <td>0.329</td> <td>46.9</td> </tr> <tr> <td>2</td> <td>1.004</td> <td>9.9</td> </tr> <tr> <td>3</td> <td>2.020</td> <td>1.0</td> </tr> </tbody> </table> | NO. | ABS. | RESULT | 1 | 0.329 | 46.9 | 2 | 1.004 | 9.9 | 3 | 2.020 | 1.0 | <p>Start method selection in the main menu. See chapter: 4.1 - Measurement with programmed methods 4.2 - Measurement with basic methods</p> <p>In the case of activated printer the print-out of the method data follows.</p> <p>The measuring window is shown.</p> <p>Method procedure: →Insert / measure zero solution</p> <p>→Insert / measure sample →Insert / measure sample →Insert / measure sample</p> |
|--|-------|--------|--------|---|-------|------|---|-------|-----|---|-------|-----|--|
| NO. | ABS. | RESULT | | | | | | | | | | | |
| 1 | 0.329 | 46.9 | | | | | | | | | | | |
| 2 | 1.004 | 9.9 | | | | | | | | | | | |
| 3 | 2.020 | 1.0 | | | | | | | | | | | |

5.4.14 Calculation procedure 14 (C/F Delta)

Method at which a difference of sample $E_2 - E_1$ is measured several times depending on the quantity of samples. In the first course the samples E_1 (maximum 25) will be measured, optionally with or without sample blank. After a user defined measure time the samples E_2 will be measured in a second course. Attention should be paid to the order within the series to avoid errors. The procedure corresponds to a fixed time kinetic.

Quality control samples can not be saved.

This calculation procedure has special parameters that allow a time controlled measuring process. These parameters are: time/delta T_1 , measure time T_2 , delay T_3 , reagent time #2 and reagent time #3. By setting a time/delta (value between 10s and 255s) the other parameters for the time controlled measuring will be used. In the time controlled mode the quantity of samples is determined by the measure time and the time/delta, e.g. with a measure time of 60s and a time/delta of 10s it is possible to measure 6 samples (without sample blank). The measure time should be chosen greater or equal the time/delta.

At the beginning of the method the use of a sample blank is queried.

After the blank is measured the time controlled measuring process will be started with [RESULT]. With a combination of acoustic signals and text messages on the display the Photometer takes control of the timing for the whole measuring. The measurement of the samples E_1 can be finished at any time with [E1/E2]. In the second course will be so many samples measured as in the first course.

Before starting a new E_1/E_2 course a new zero measurement has to be done.

The reagent time #3 is usable only if the reagent time #2 is set. In that case the reagent mode will be entered, i.e. the photometer also takes control of the timing for dispensing the reagent before measuring the samples and the quantity of samples will be determined by the reagent time #2 and the time/delta. The reagent time #2 should be chosen smaller or equal the reagent time #3 and greater or equal the time/delta.

Figure 5.4.14.1 shows the time sequence of a time controlled measuring process with N samples, a delay time T_3 and without reagent time.

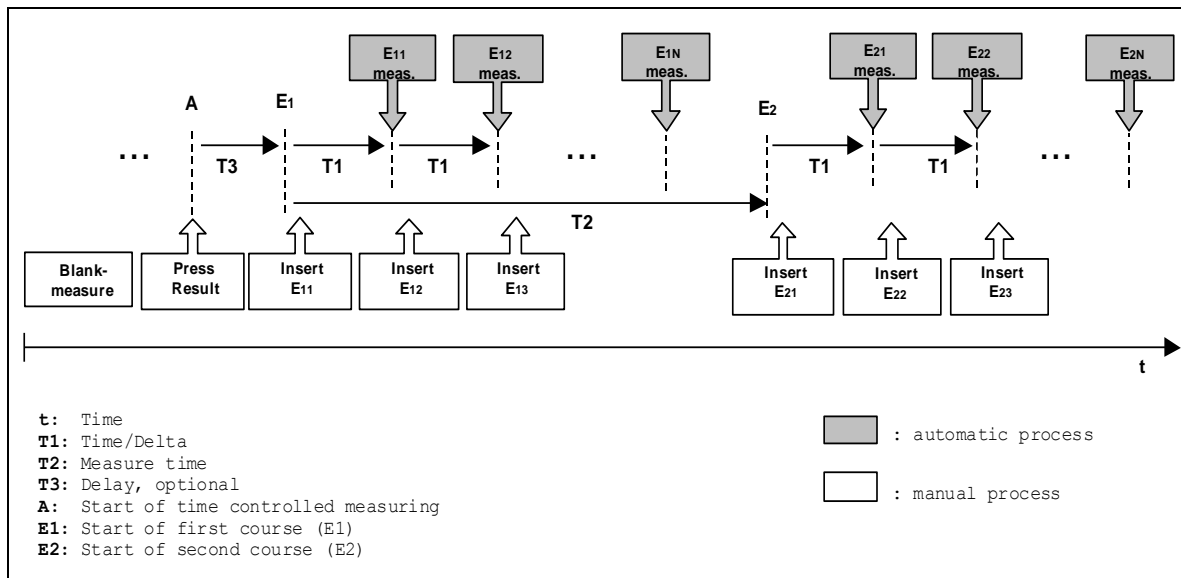

Fig. 5.4.14.1: time controlled measuring

Calculation procedureCP 14
 Characteristic C / F / Delta
 MethodDifference with Factor
 Calculation formula $C = F * (\Delta A_{S2-Sb2} - \Delta A_{S1-Sb1})$
 Factor given / entering
 Sample blank with / without
 Time / Delta T1entering (0, 10s to 255s)
 Measure time T2entering (0 to 1800s)
 Delay T3entering (0 to 1800s)
 Reagent time #2entering (0 to 1800s)
 Reagent time #3entering (0 to 1800s)

| | |
|---|---|
| <pre> PHOTOMETER 680 # 3000 V7.Xa dd/mm/yy D LAB.: RIELE BERLIN USER 1: M.MUSTERMANN DATE: 03/18/20 TIME: 08:44:12 METHOD 14: C/F DELTA PROGRAM: 14 FACTOR: 1.000 WAVELENGTH: 405nm TIME/DELTA: 12s MEASURE TIME: 100s DELAY: 10s REAGENT 2: 40s REAGENT 3: 60s UNIT: U/l ----- MEASURE ZERO NO. Sb[A] S[A]E1 1 0.083 0.411 2 0.110 0.382 3 0.146 0.492 NO. Sb[A] S[A]E2 1 0.091 1.090 2 0.140 0.991 3 0.200 1.165 NO. RESULT 1 0.671 2 0.578 3 0.619 NO. Sb[A] S[A]E1 1 0.000 1.012 2 0.000 1.138 3 0.000 1.076 NO. Sb[A] S[A]E2 1 0.000 1.458 2 0.000 1.530 3 0.000 1.384 NO. RESULT 1 0.446 2 0.392 3 0.307 </pre> | <p>Start method selection in the main menu. See chapter: 4.1 - Measurement with programmed methods 4.2 - Measurement with basic methods</p> <p>In the case of activated printer the print out of the method data follows.</p> <p>The measuring window is shown.</p> <p>Method procedure with sample blank: →Insert / measure zero solution →Measure all samples E1 (maximum 25) →Change to measuring E2 by [E1/E2] →Measure all samples E2 (maximum 25)</p> <p>Results based on the differences of the measured samples</p> <p>→Show the results by [MODE] [MODE] [DETAIL]</p> <p>Method procedure without sample blank: →Measure all samples E1 (maximum 25) →Change to measuring E2 by [E1/E2] →Measure all samples E2 (maximum 25)</p> <p>Results based on the differences of the measured samples</p> <p>→Show the results by [MODE] [MODE] [DETAIL]</p> |
|---|---|

5.4.15 Calculation Procedure 16 (DELTA R1R2)

Method for two endpoint assays to calculate the difference in absorbance (E1 and E2) after addition of two reagents R1 and R2 to a sample. E1 represents the absorbance of a sample in addition with reagent 1 (R1) just before a second reagent (R2) is added. E2 is the absorbance after adding R2. The course of the procedure is outlined in Fig. 5.4.16.1.

The maximum number of samples depends on the length of the measure time of reagent 1 and 2 (T2 and T3). The number of samples may be reduced by pushing [->R2] before starting the measurement or by skipping of further samples during the first pipetting phase.

During the procedure the user is guided by indications on the screen (draw up and dispense reagent, etc., see Fig. 5.4.16.2) and acoustic signals.

The factor F_{dil} is the volume correction factor which is calculated on the basis of the given volumes (sample volume (a), R1 volume (b) and R2 volume (c) on page 3/3 of the method parameters). The factor is set to 1.000 by default when given volumes are not set.

$$\Delta A_s = E_2 - F_{dil} * E_1$$

whereby $F_{dil} = (a + b) / (a + b + c)$

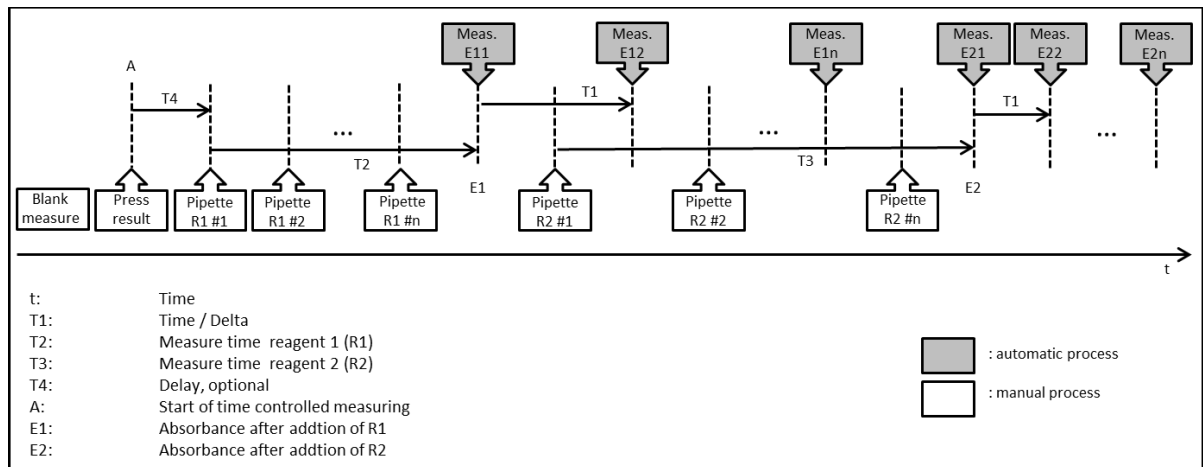

Fig. 5.4.16.1: time controlled measuring

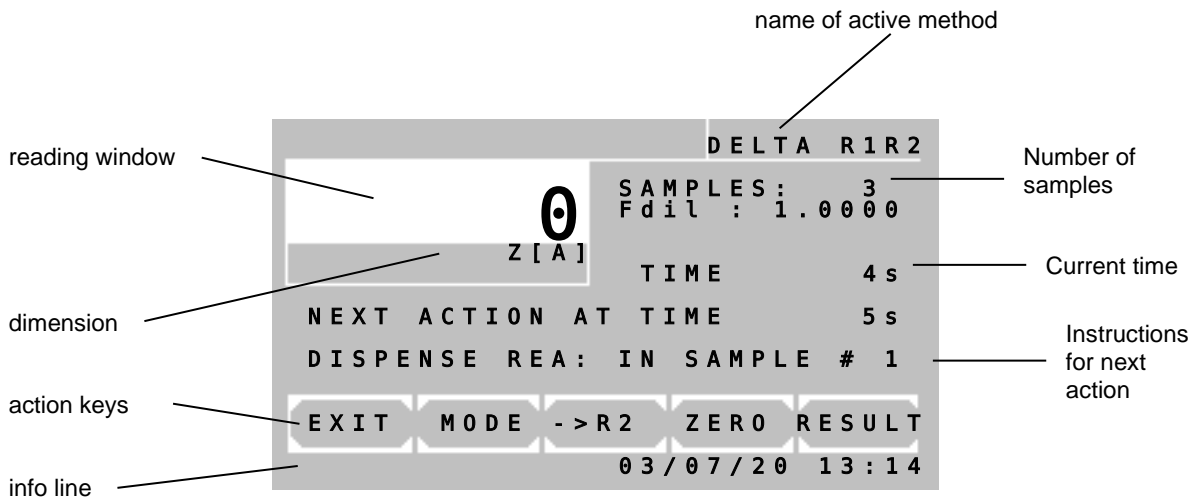

Fig. 5.4.16.2: screen during the method

Calculation procedureCP 16
 CharacteristicDELTA R1R2
 Method Difference measurement of two reagents
 Calculation formula $C = \Delta A_s$
 Factor given / entering
 Time / Delta T1entering (20 to 255s)
 Measure time R1 T2entering (0 to 1800s)
 Measure time R2 T3entering (0 to 1800s)
 Delay T4entering (0 to 1800s)

| | |
|---|---|
| <pre> PHOTOMETER 680 # 3000 V7.Xa dd/mm/yy D LAB.: RIELE BERLIN USER 1: M.MUSTERMANN DATE: 03/18/20 TIME: 08:44:12 METHOD 20: DELTA R1R2 PROGRAM: 16 FACTOR: 1.000 WAVELENGTH: 546nm TEMPERATURE: 37C TIME/DELTA: 30s DELAY: 0s TIME REA.#1 130s TIME REA.#2 130s UNIT: - - - - - MEASURE ZERO E1 1 0.285 [A] E1 2 0.285 [A] E1 3 0.285 [A] E2 1 0.165 [A] E2 2 0.165 [A] E2 3 0.165 [A] NO. RESULT 1 -0.116 2 -0.116 3 -0.116 </pre> | <p>Start method selection in the main menu. See chapter: 4.1 - Measurement with programmed methods 4.2 - Measurement with basic methods</p> <p>In the case of activated printer the print out of the method data follows.</p> <p>The measuring window is shown.</p> <p>→Insert / measure zero solution</p> <p>→Insert / measure samples with reagent 1</p> <p>→Insert / measure samples with reagent 2</p> <p>The user is guided through the measuring procedure on the screen.</p> <p>→The result will be displayed</p> |
|---|---|

6 METHOD EDITOR

By the method editor the daily laboratory work can be substantially facilitated. Based on the 12 calculation procedures up to 231 user-defined methods with their setting parameters can be saved. With the functions of the editor a method can be established, changed or deleted.

Fig. 6.1

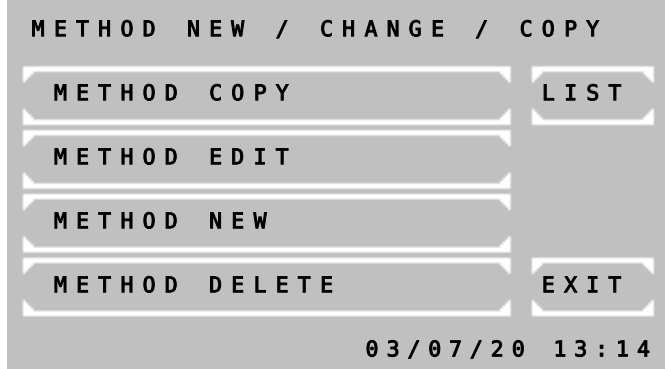

In the main window of the method editor following options are available:

[METHOD COPY] Change to [Fig. 6.2](#), where different copy functions can be selected.

[METH. EDIT] Change to [Fig. 6.3](#), where the number of the method to be edited is queried. Afterwards all setting parameters of the selected method can be changed.

[METHOD NEW] Change to selection of the calculation procedure (see 5.3 SURVEY OF THE METHODS). In [Fig. 6.4](#) all setting parameters can be edited.

[METHODE DELETE] Change to [Fig. 6.3](#), where the number of the method to be deleted is queried. After a prompt for confirmation the selected method is deleted. (Basic and fixed methods cannot be deleted).

[LIST] A list of all programmed methods can be printed and transmitted via the serial interface.

[EXIT] Return to main menu

Print-out of a method list:

```
METHOD 20:  HEMOGLOBIN
F 29.4 405nm  g/dl

METHOD 21:   HDL-C
F 1.000 546nm  mg/dl

METHOD 30:   CREATININ
S 2.0 492nm  mg/dl
```

Fig. 6.2

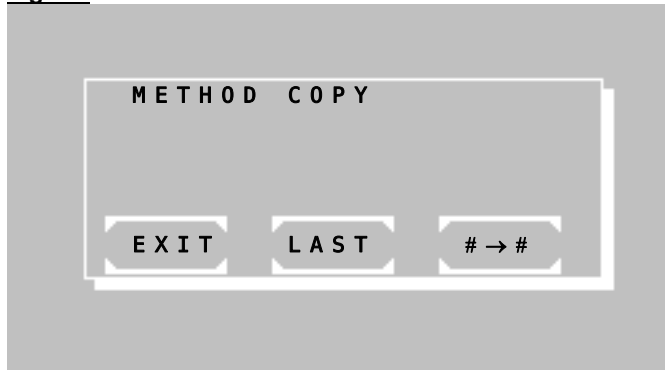

[#->#] All methods from no 20 can be copied to a new method no. First the method to be copied is queried in [Fig. 6.3](#). Its parameters can be changed starting with [Fig. 6.4](#).

[LAST] The method used last can be copied on a new method place. Its setting parameters can be changed starting with [Fig. 6.4](#).

This function is very useful if a basic method with new setting parameters was successfully tested. These parameters can be saved as a new method starting from no 20.

[EXIT] Return to main menu

Fig. 6.3

Inquiry window of the desired method.

The method used last is suggested. With [+] or [-] the methods can be scrolled. A numeric input of the method number is possible at any time. A known method is indicated with name and dimension.

[E] Select shown method

[ESC] Return to main menu

Fig. 6.4 (parameter window 1)

The parameter windows 1 and 2 show the general method data.

The parameter window 3 has special functions which are necessary for quality control only (see below).

For each setting parameter a leading identification number is shown. If the identification number is selected on the keyboard, the corresponding setting parameter becomes configurable.

Number and kind of setting parameters depend on the calculation procedure. So identification numbers can be occupied variedly. Characteristic numbers without parameters do not have a function.

Fig. 6.5 (parameter window 2)

[EXIT] Return to main menu

[OK] Accept setting parameters (depending on editor mode sometimes with query of target method)

[S./3] Change to next parameter window

Fig. 6.6 (parameter window 3)

Specifics in parameter window 3:

At least one control serum must be defined, before data can be entered (see chapter 7.2.6 Quality control).

If at least one control serum with its setpoint and range is entered, corresponding memory of the quality control is reserved for this method. So it can be supervised with integrated quality control.

i If both ID identifications are deleted, then also all data and reserved memory of this method in the quality control are deleted!

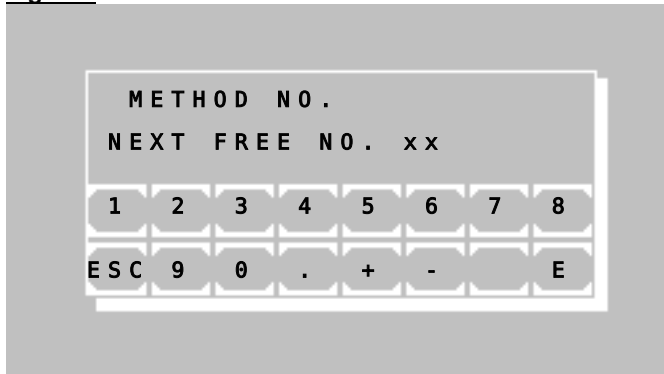
Fig. 6.7

Query of the desired method number, under which the new method is to be stored. The next free method number is indicated. However each free method number can be selected within the range of 20 to 250.

[E] Store method with selected number. In case of multi-standard method [Fig. 6.8](#) follows.

[ESC] Break storage and return to editor menu

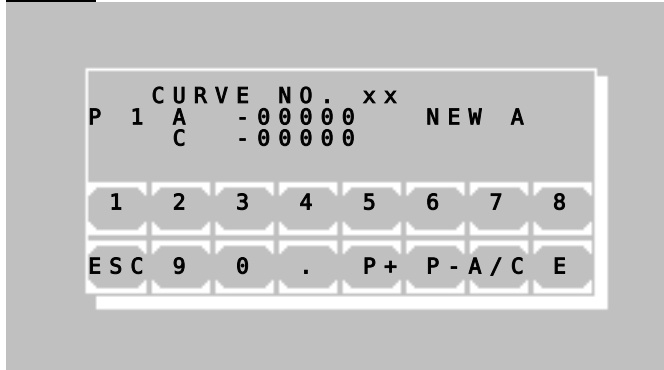
Fig. 6.8

For a method with multi-standard there is the editor window for the curve bases.

[P+] and [P-] Consecutive numbering of the current bases

[A/C] Switch input between A for absorbance and C for concentration

[E] Accept the edited value



Input and confirmation of a single "0" at A lead to the deletion of the current pair of points. In order to set the value to zero enter e.g. "0.0".

[ESC] End input and save curve data



For measuring in a multi-standard method at least 2 bases with A and C must be defined!

7 UTILITY PROGRAMS

7.1 SELECTION OF UTILITY PROGRAMS

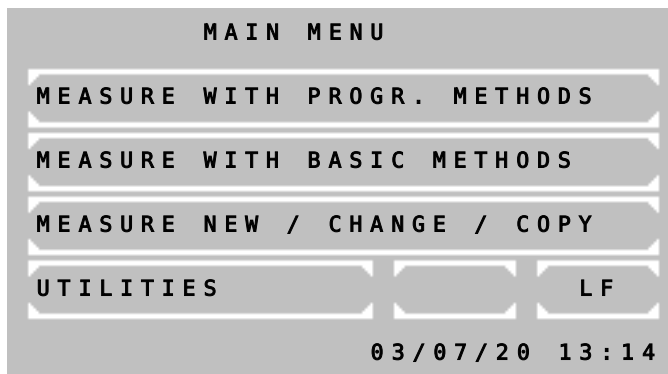

Main menu:

Utility programs are necessary for the adjustment and maintenance of the photometer.

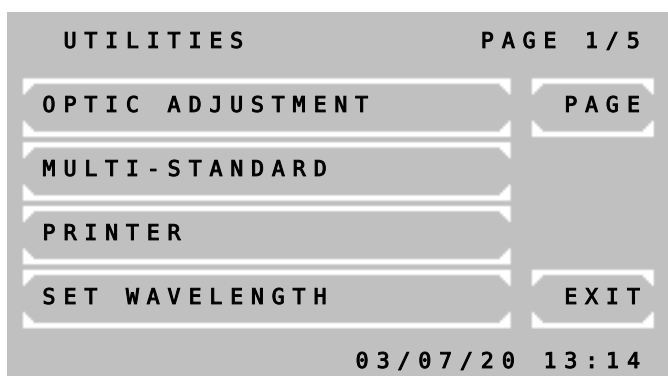

Page 1 of utility programs:

Scrolling through all utility programs is possible by [PAGE]. The current page is shown at the right upper screen corner. By [EXIT] the program returns to the main menu.

A utility program is selected by pressing the relating key.

| Utilities | Description in chapter |
|--------------------------|------------------------|
| Optic adjustment | 7.2.1 |
| Multi-standard functions | 7.2.2 |
| Printer ON / OFF | 7.2.3 |
| Set wavelength | 7.2.4 |
| Menu serial | 7.2.5 |
| Quality control | 7.2.6 |
| Settings printout | 7.2.7 |
| Stored results | 7.2.8 |
| Laboratory name | 7.2.9 |
| User name | 7.2.10 |
| Error list | 7.2.11 |
| Key signal ON / OFF | 7.2.12 |
| Touchscreen adjustment | 7.2.13 |
| Date / Time | 7.2.14 |
| Language | 7.2.15 |
| ADC counts (Optic) | 7.2.16 |
| Bar Code | 7.2.17 |
| Service tools | 7.2.18 |

7.2 DESCRIPTION OF UTILITY PROGRAMS

7.2.1 Optic adjustment



The optic adjustment should be done not before the warm-up time of 15 minutes has passed, better after one hour operation.



Use any filter turned over with the glass side up.

Start the optic adjustment by [START].

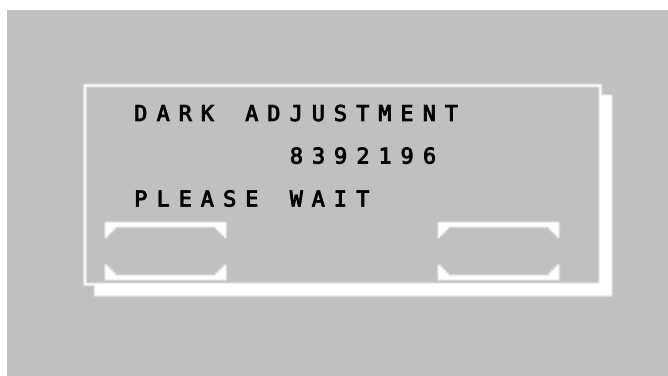

Calibration of the dark level.

Wait for about 40s until adjustment is finished.

The function cannot be interrupted. After completion the program returns to the utility program level.



Monthly executed the optic adjustment compensates possible deviations of the measuring accuracy due to environmental influences.

7.2.2 Multi-standard functions

Before curve data of a method with multi-standard can be processed, the method must have been established in the method editor (chapter 6 - METHOD EDITOR). A curve without corresponding method cannot be processed! The term "curve no" has the same meaning as "method no".

If using a multi-standard method later on, pay attention that all extinction values of the samples lie within the absorbance/extinction range of the curve bases. Values outside of the absorbance/extinction range cannot be calculated. In this case "+-" is shown and "<<< >>>" printed instead of the reading.

Fig. 7.2.2.1

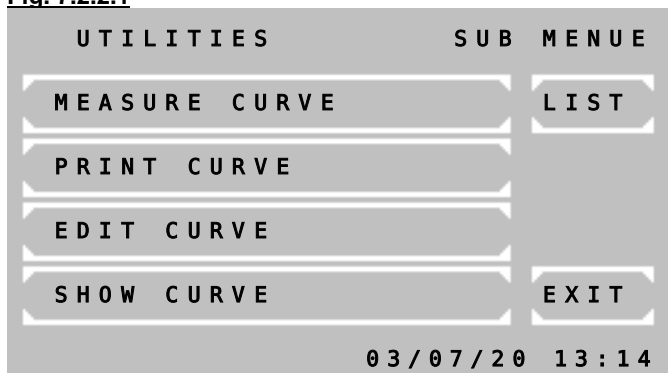

Main window of multi-standard functions

[MEASURE CURVE] After query of a curve number and the first standard the program changes automatically to the method selection window. There the given parameters of the respective method can be again controlled and/or changed. All further standards are queried during the following procedure.

The program for measuring the multi-standards branches out automatically to the calculation procedures as follows:

CP1 → CP5
 CP2 → CP6
 CP3 → CP7
 CP4 → CP8
 CP9 → CP10
 CP14 → CP14

CURVE: 20
23/09/11

| NO. | ABS. | CONC. |
|-----|-------|-------|
| 1 | 0.302 | 60 |
| 2 | 0.6 | 30 |
| 3 | 0.92 | 15 |
| 4 | 1.16 | 7.5 |
| 5 | 1.501 | 3.25 |

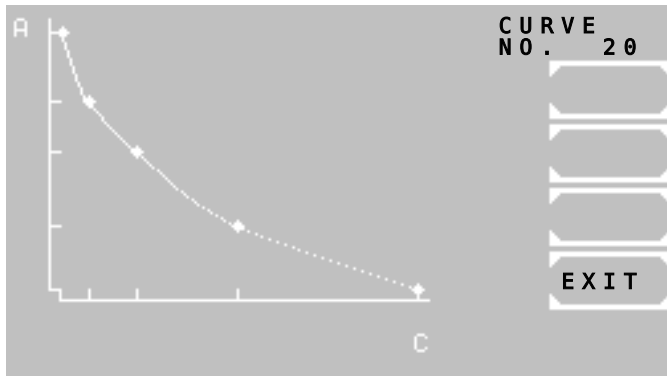
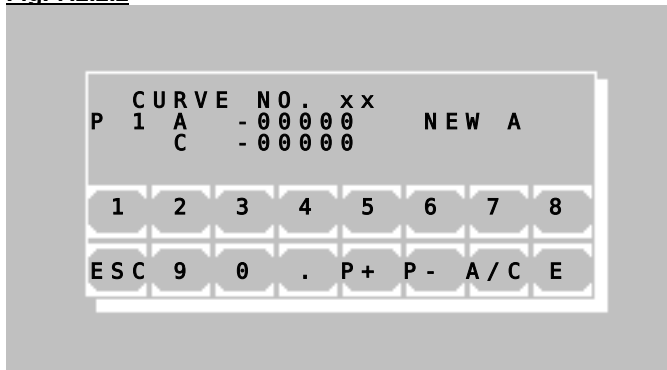

Fig. 7.2.2.2



i For measuring in another standard method than suggested, start measuring multi-standards in each other selected standard method (before measuring the first standard) by [MODE] [MODE] [M-STD]. Curve number and standards are queried accordingly.

i For measuring in a multi-standard method at least two standards with A (absorbance/extinction) and C (concentration) must be defined!

[PRINT CURVE] After inquiry of the curve number print-out on the internal printer or via the serial interface.

[EDIT CURVE] After inquiry of the curve number all standard values can be edited, added or deleted (see fig. 7.2.2.2).

[SHOW CURVE] After inquiry of the curve number the function will be shown. The standards are represented by squares.

[LIST] The method number and the date of preparation of all current curves are shown.

[EXIT] Return to the utilities

[P+] and [P-] Consecutive numbering of the current standard values.

[A/C] Switch input between: A (absorbance/extinction) and C (concentration).

[E] Accept the edited value

i Input and confirmation of a single "0" at A (absorbance/extinction) lead to the deletion of the current standard. In order to set the value to zero enter e.g. "0.0".

[ESC] End input and save curve data. The standards are sorted in ascending order according to their A (absorbance/extinction) value.

7.2.3 Printer ON / OFF

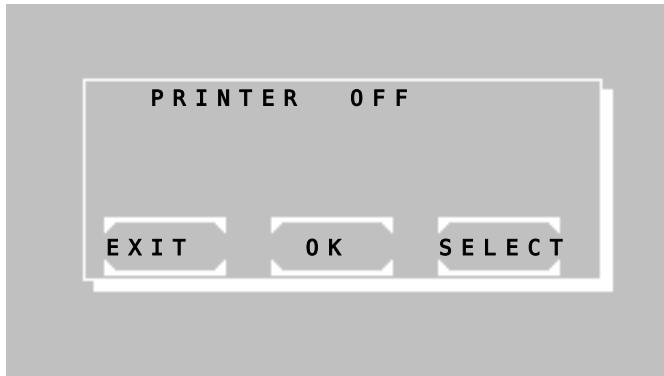

The current status of the internal printer is indicated in the first line by OFF or ON.

Change setting by [SELECT]

Save setting permanently by [OK]

Save setting temporarily up to next switch-off of the device by [EXIT]

| NO. | ABS. | RESULT |
|-------|-------|----------|
| 1 | 0.675 | 19.8 |
| TIME: | | 11:21:32 |



When printer ON via [MODE] [PRN] after a measurement the current time can be printed out by [TIME].

7.2.4 Set wavelength

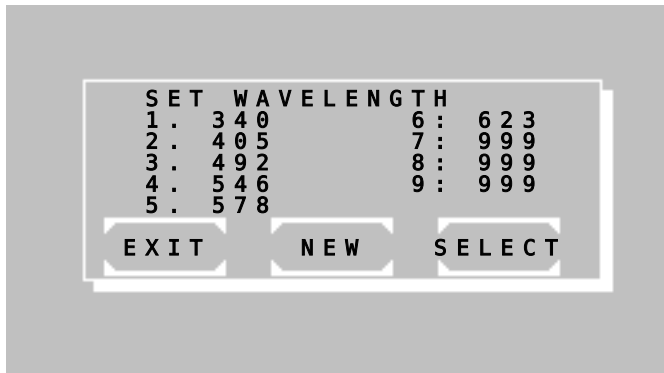

The optical filters used with Photometer 680 can be declared.

The current filter is blinking.

With [SELECT] the filter can be set.

With [NEW] the value of the wavelength can be edited.

[EXIT] leaves the function without any changes.

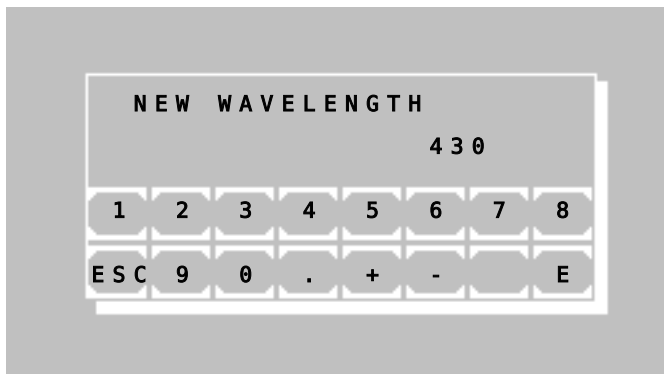

In the second line the value (e.g. 430 nm) of the filter is shown.

A new value of the wavelength can be edited.

The input has to be confirmed with [E].

[ESC] leaves the function without any changes.

7.2.5 Menu serial COM

A PC or an external printer can be connected to Photometer 680 via the RS 232 serial interface at the back. A suitable data cable can be supplied (REF 501-002). The connected device must comply with safety standard EN 60950.

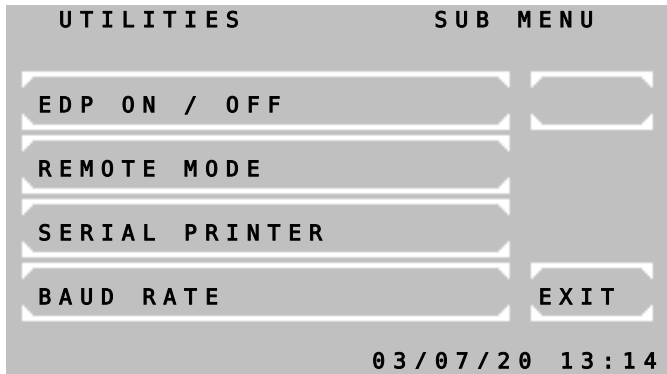

The menu offers following functions:

- Activation and deactivation of EDP
- Activation of remote control
- Activation or deactivation of external printer with serial interface
- Setting of baudrate

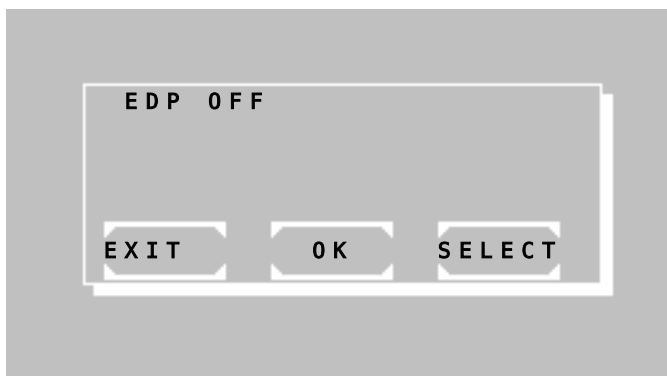

7.2.5.1 EDP ON/OFF

The current status of the EDP (Electronic Data Processing) interface is indicated in the first line by OFF or ON.

Change setting by [SELECT]:

- EDP OFF: no output,
- EDP ON (CR-LF): system output through serial port with CR-LF protocol,
- EDP ON (STX-ETX-BCC): system output through serial port with STX-ETX-BCC protocol,
- EDP ON (CR-LF-LOG): after each measurement a formatted string will be output through the serial port. (e.g. see table. 7.2.4.1)

Save setting permanently by [OK]

Save setting temporarily up to next switch-off of the device by [EXIT]

Table 7.2.5.1

| Serial no. | Method no. | ID-no. | Sample no. | Result | reserved | User | Date | Time |
|------------|------------|--------|------------|--------|----------|-------------|----------|----------|
| 2250 | 20 | 12345 | 1 | 15.5 | | [user name] | 09/08/09 | 09:30:47 |

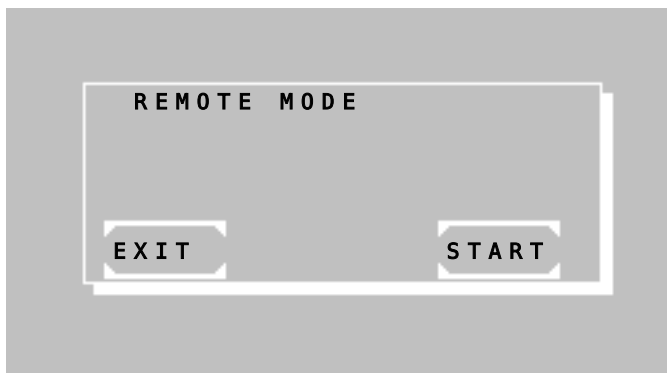

7.2.5.2 REMOTE CONTROL

Activate remote control by [START].

When activated, Photometer 680 can be remote-controlled by a PC and a suitable program.

Deactivate remote control by sipping lever [P].

By [EXIT] the program returns to the superordinate menu item.

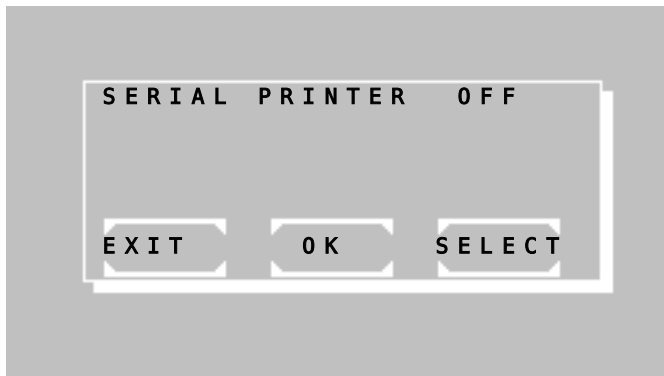

7.2.5.3 SERIAL PRINTER ON / OFF

The current status of the external serial printer is indicated in the first line by OFF or ON.

Change setting by [SELECT]

Save setting permanently by [OK]

Save setting temporarily up to next switch-off of the device by [EXIT]

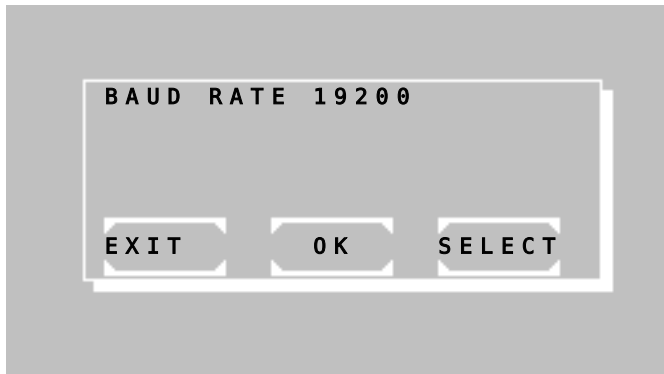

7.2.5.4 BAUDRATE

The current baudrate is shown in the first line.

Change setting by [SELECT].

Save setting permanently by [OK].

Discard changes by [EXIT].

7.2.6 Quality control

In Photometer 680 up to 50 methods can be supervised with a quality control. The device can manage up to 6 control serums. Each QC supervised method can be connected with 2 control serums. The QC data of a series of measurements are stored in a daily memory. Each reading is stored with method number, date and user identification. From the daily memory the individual QC data can become deleted or saved in the monthly memory of the corresponding method. The monthly memory of a QC method can record up to 31 readings. With the 32nd the oldest reading is deleted in the memory. For the calculation of the quality values of a method at least 20 readings in the monthly memory must be present. The average of all readings, the standard deviation and the coefficient of variation are calculated. Contents of the daily and monthly memory can be indicated and printed out.

Except the basic methods all methods can be connected with a quality control. The method-typical data of a control serum are entered via the method editor (see chapter 6 METHOD EDITOR).

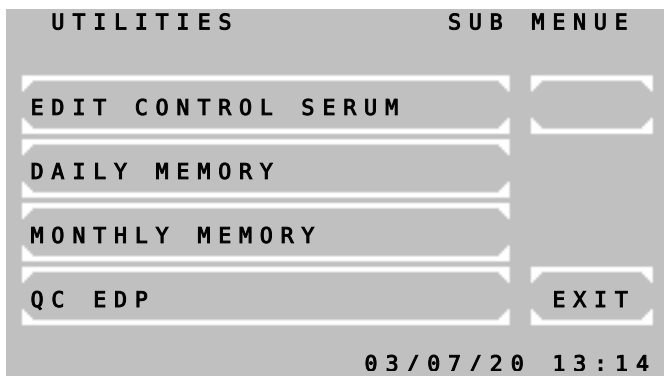

The QC menu offers following functions:

[EDIT CONTROL SERUM] Up to 6 control serums can be defined. Without a defined serum the QC cannot be started!

[DAILY MEMORY] View, print and processing of the daily memory for serum 1/2

[MONTHLY MEMORY] View, print and processing of the monthly memory for serum 1/2

[QC EDP] - not implemented -

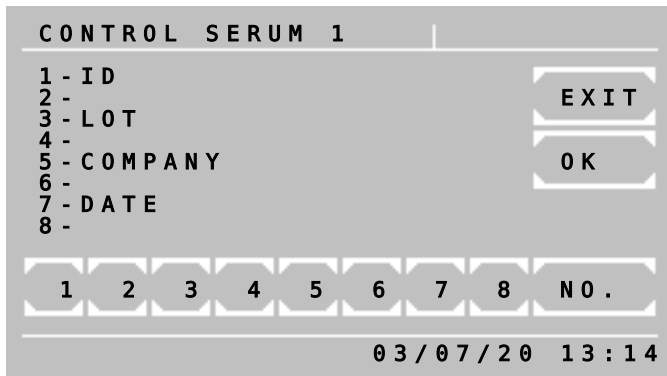

7.2.5.1 INPUT OF CONTROL SERUM

- [1] Enter name max 15-digit
- [3] Enter LOT no max 10-digit
- [5] Enter company max 10-digit
- [7] Enter expiry date max 8-digit
- [NO.] Change to next control serum
- [EXIT] and [OK] Accept input and return to QC menu

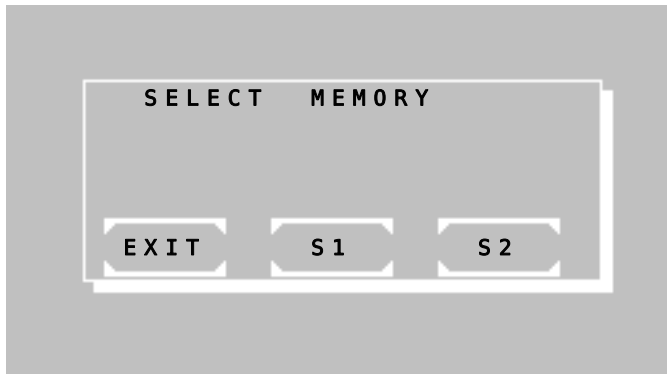

7.2.5.2 DAILY MEMORY

- [S1] Select daily memory for serum 1
- [S2] Select daily memory for serum 2
- [EXIT] Return to previous window

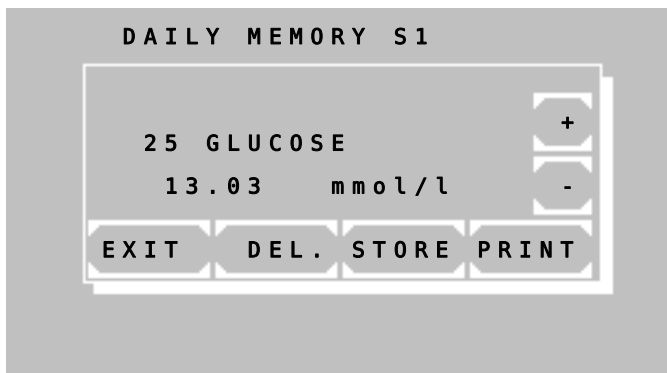

- Measuring data of the corresponding daily memory are shown with method number, method name, reading and dimension.
- [+] Change to next reading
- [-] Change to previous reading
- [DEL] Delete shown reading in the daily memory and confirm again by [DEL]
- [STORE] Store shown reading in the daily memory and confirm again by [STORE]. Afterwards the reading is deleted in the daily memory.

Print-out of daily memory for serum 1:

```

*** DAILY MEMORY ***S1 *
PHOTOMETER 680 # 3000
V7.Xa dd/mm/yy D
LAB.: RIELE BERLIN

DATE:          03/18/20
TIME:          08:44:12

25 GLUCOSE      13.03
21 HDL-C        367
27 UREA COL     197.2
    
```

- [PRINT] Print all readings
- [EXIT] Return to QC menu

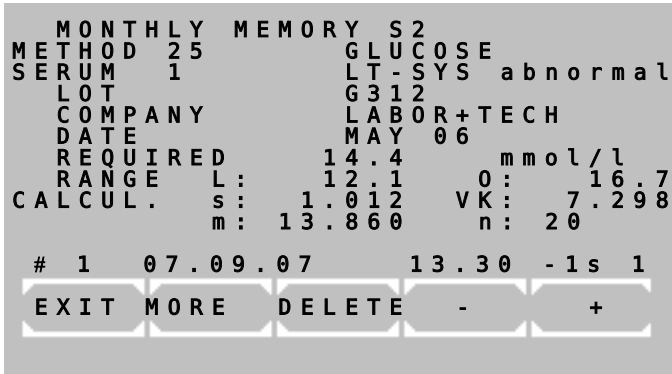
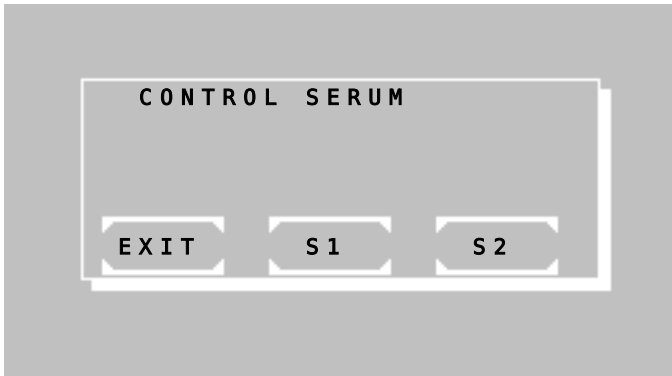

7.2.5.3 MONTHLY MEMORY

After query of method number select serum 1 or 2 of the method.

[S1] Select monthly memory for serum 1

[S2] Select monthly memory for serum 2

[EXIT] Return to previous window

In the overview window of the selected method all data of quality control are visible. In the line above the keys following information the current reading is indicated:

(# 1) → Numerator of the monthly memory. The oldest reading corresponds to the 1.

(01.27.06) → Date of reading

(13.30) → Reading

(-1.s) → Deviation of the reading lies within minus 1s. From +/-3s the warning level starts. With a deviation of > 3s an * is displayed. For the calculation of the quality values of a method at least 20 readings in the month memory must be present!

(1) → User identification

The keys have following functions:

[+] Change to next reading

[-] Change to previous reading

[DEL] Delete all measuring data of the monthly memory of the selected method and confirm again (e.g. at change of serum)

[MORE] Change to output dialog

[EXIT] Return to QC menu

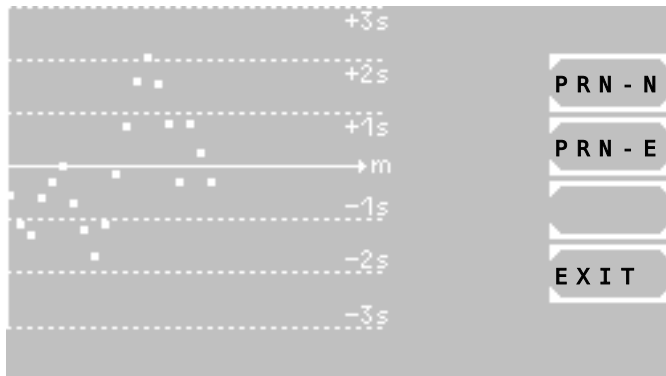

Printout of the monthly memory of a method with serum 2:

```

** MONTHLY MEMORY **S2 *
DATE:                03/18/20
PHOTOMETER 680      # 3000
V7.Xa dd/mm/yy D
LAB.: RIELE BERLIN
METHOD 25: GLUCOSE
UNIT:                mmol/l
SERUM NO. 5
  ID      LT-SYS abnormal
  LOT     G312
  COMPANY LABOR+TECH
  DATE    MAY 11
  REQUIRED          14.4
  MIN.VALUE       12.1
  MAX.VALUE       16.7
QC VALUES      n: 20
MEAN            m: 13.860
STD.DEVIATION  s: 1.012
COEFF.OF VAR CV: 7.298
02/15/10      13.54 -1s 1
02/14/10      14.07 +1s 1
02/13/10      14.69 +1s 1
02/12/10      13.50 -1s 3
02/11/10      14.68 +1s 3
02/10/10      15.33 +2s 1
02/09/10      15.99 +3s 1
02/08/10      15.38 +2s 2
02/07/10      14.61 +1s 1
02/06/10      13.70 -1s 1
02/05/10      12.74 -2s 1
02/04/10      12.13 -2s 1
02/03/10      12.65 -2s 2
02/02/10      13.11 -1s 1
02/01/10      13.88 +1s 3
01/31/10      13.51 -1s 3
01/30/10      13.24 -1s 3
01/29/10      12.50 -2s 1
01/28/10      12.74 -2s 2
01/27/10      13.30 -1s 1

```

Output dialog

If at least 20 readings are stored in the monthly memory, these are indicated in the Levey Jennings plot. In this representation the deviations can be controlled visually and thus tendencies or systematic errors be better recognized.

The keys for the printout are located next to the curve diagram:

[PRN-N] Start the normal printout of the data of the current monthly memory. The single data of the readings are not printed thereby.

[PRN-E] Start the extended printout of the data of the current monthly memory. As shown in the example left, also the single data of the readings are printed.

[EXIT] Return to QC menu

7.2.7 Settings printout

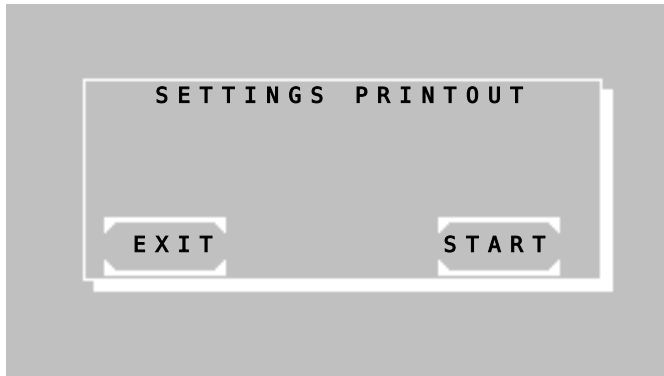

By [START] the program version and the complete status of the saved settings are printed out.

```

*****ACTUAL*SETS*****
DATE:          03/29/20
TIME:          12:15:52
PHOTOMETER 680 # 3003
V7.6a 06/03/2020 /T1.8
CORE 416 V1.2
PCB LAYOUT          c
ADC COUNTS (DARK ADJ.)
  N: 8390598   B: 8389912
FILTER
  1: 340   2: 405   3: 492
  4: 546   5: 578   6: 623
  7: 999   8: 999   9: 999
BATTERY:         OK
EDP ON          (CR-LF)
TOUCH
  Mx138 My183 Fx136 Fy107
LANGUAGE
  en fr de es id
KEY SIGNAL ON
T.COUNTER :          26:57
S.COUNTER :           40
PROGR. METHODS      2
STORED RESULTS      26
  
```

7.2.8 Stored results

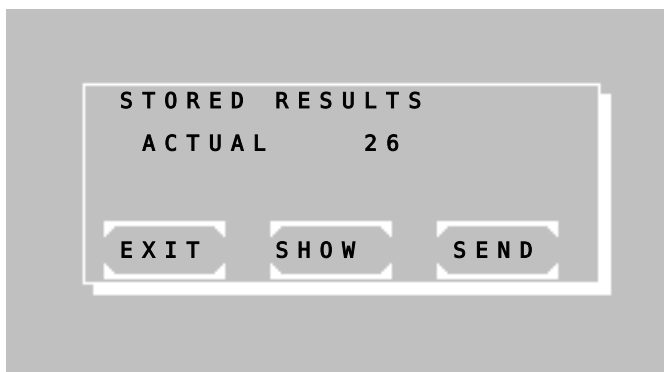

[EXIT] terminates the program.

[SHOW] indicates stored data step by step.

[SEND] transmits stored results through the serial port.

After transmitting is completed you will be prompted to delete stored results. Press [START] to delete results or [EXIT] to exit without deleting results.

7.2.9 Laboratory name

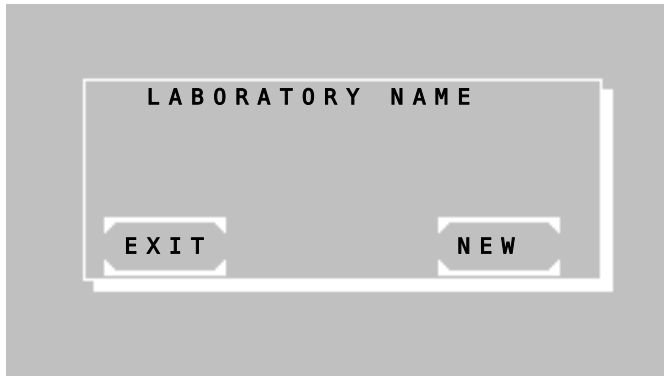

The name of the laboratory can be stored permanently.

In case of a stored name an additional line within the header is sent to the printer or to the EDP.

By [NEW] the entry of the laboratory name is possible.

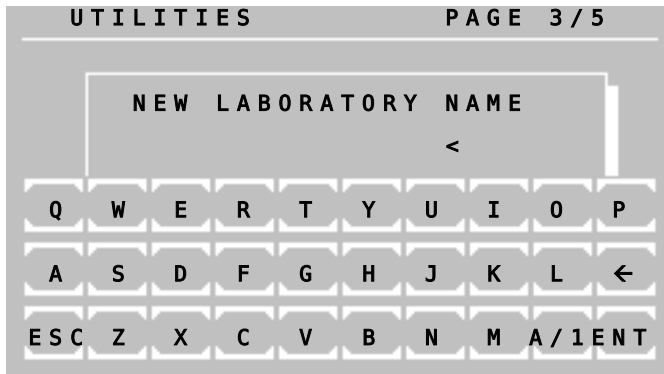

Enter the laboratory name via the alphanumeric keyboard.

Following functions are available:

- [a/1] : change to lowercase
- [1/A] : change to numeric characters
- [A/a] : change to uppercase
- [←] : delete character
- [→] : blank
- [ESC] : finish input without storage
- [ENT] : finish input with storage

7.2.10 User name

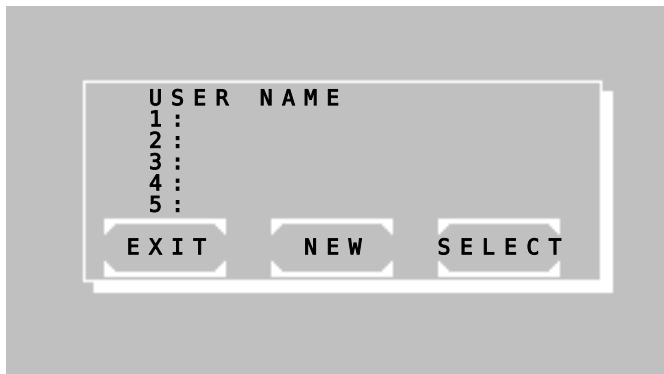

The names of maximum five users can be stored permanently.

After calling a method the user is queried.

In case of a stored name an additional line within the header is sent to the printer or to the EDP.

Select user by [SELECT]. By [NEW] the entry of the user name is possible.

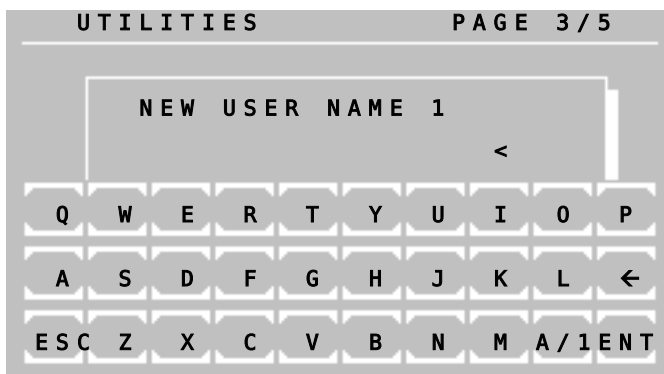

Enter the user name via the alphanumeric keyboard.

Following functions are available:

- [a/1] : change to lowercase
- [1/A] : change to numeric characters
- [A/a] : change to uppercase
- [←] : delete character
- [→] : blank
- [ESC] : finish input without storage
- [ENT] : finish input with storage

7.2.11 Error list

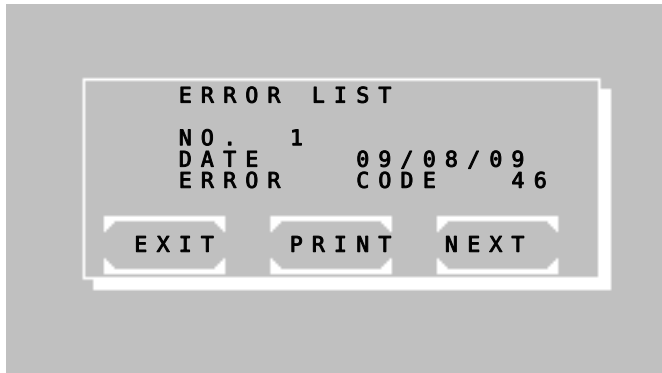

The last 10 serious errors are shown or printed.

The oldest error is shown first. The last error is always marked with no 1.

By [NEXT] earlier error messages are shown.

By [PRINT] the complete error list is printed or output to the serial interface.

For troubleshooting the coded error list can be consulted (chapter 9.4 - CODED ERROR MESSAGES).

7.2.12 Key signal ON / OFF

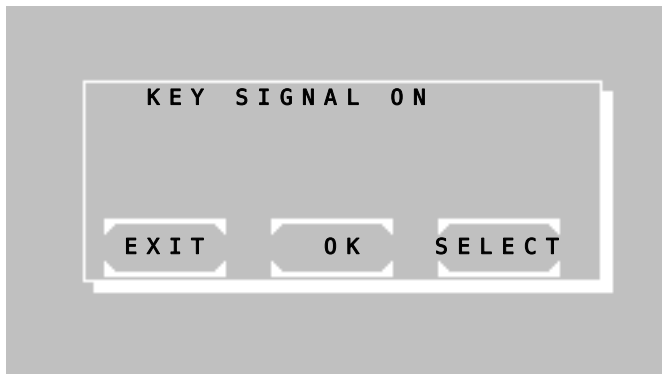

The current status of the key signal is indicated in the first line by OFF or ON.

Change setting by [SELECT].

Save setting permanently by [OK].

Save setting temporarily up to next switch-off of the device by [EXIT].

The deeper signal tone for error messages remains active in any case.

7.2.13 Touchscreen adjustment

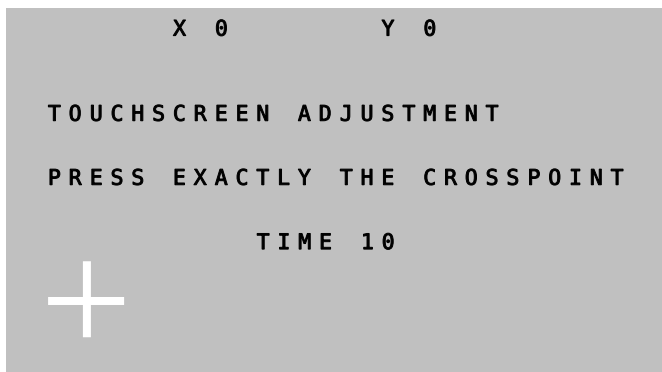

By this function the touchscreen can be adjusted. After call of the function a white cross is shown in the left lower corner of the screen. Touch the intersection point in the screen. Touch the intersection point in the cross with a non-scratching plastic tip (touchscreen pen, pipette tip) as exactly as possible. In the first line the coordinates are shown as X- and Y-value. The input will be accepted and the coordinate display will be reset after a time out of 10s. Then the cross is shown in the right upper corner. Touch the intersection point. After a timeout of 10s the memory inquiry follows.

Save the adjustment by [OK].

Reject the adjustment by [EXIT].

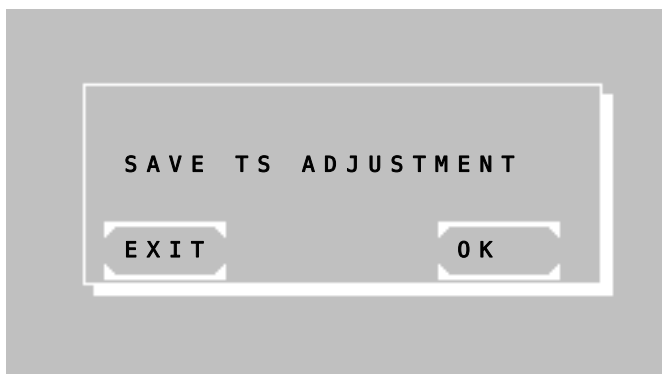



Hint: If the device is maladjusted, this function can directly be called during the switching on routine:

Switch on the device. While greeting screen (chapter 2.3 - INSTALLATION) is displayed keep the touchscreen pressed until a deep signal tone sounds and the text message "TOUCHSCREEN ADJUSTMENT" is shown in the first line of screen. Release the touchscreen within one second. Execute the adjustment of the touchscreen as described above. Select the type of photometer after touchscreen adjustment is completed.

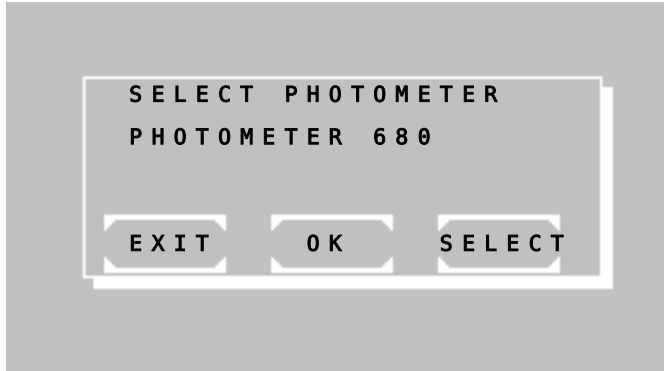

Select type of photometer:

Reject setting by [EXIT].

Save setting permanently by [OK].

With [SELECT] the type of photometer is selected.

7.2.14 Date / Time

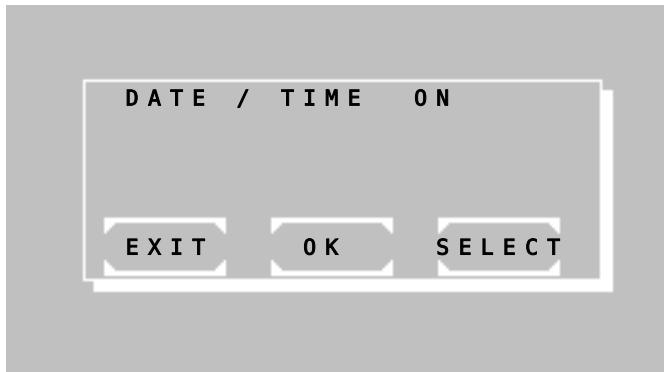

The current status of the date/time display is indicated in the first line by OFF or ON.

Change setting by [SELECT].

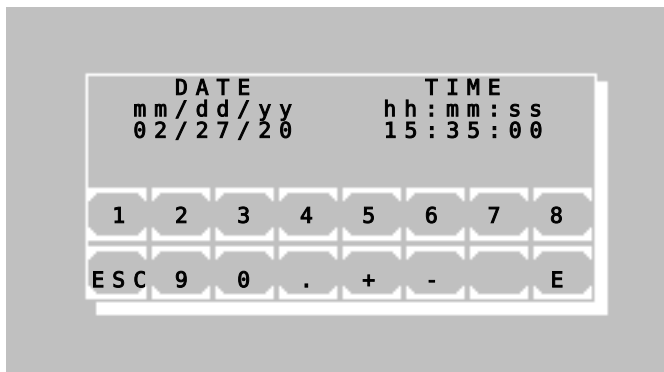

With activation of the clock date and time can be changed by [OK]. Each entry of day, month, year, minute and second must be confirmed by [E].



If a value is to be changed, then all values are to be entered again!

7.2.15 Language

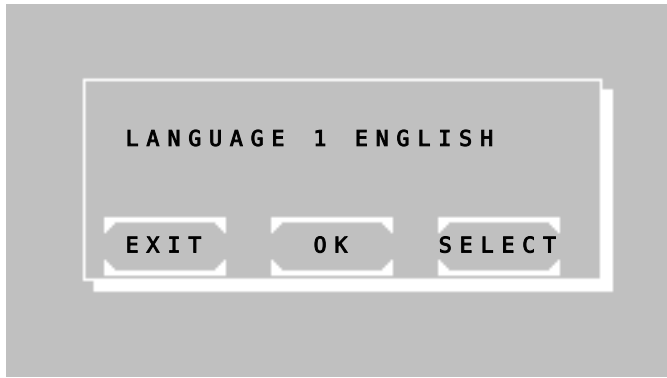

The current status of the language is indicated in the first line.

The setting can be changed by [SELECT] Following options are possible:

- LANGUAGE : ENGLISH
- LANGUAGE : FRANCAIS
- LANGUAGES 3, 4 und 5 optional
- LANGUAGE 6: Download-Funktion

Save setting permanently by [OK].

The setting is temporarily saved up to next switch-off of the device by [END].

7.2.16 ADC counts (Optic)

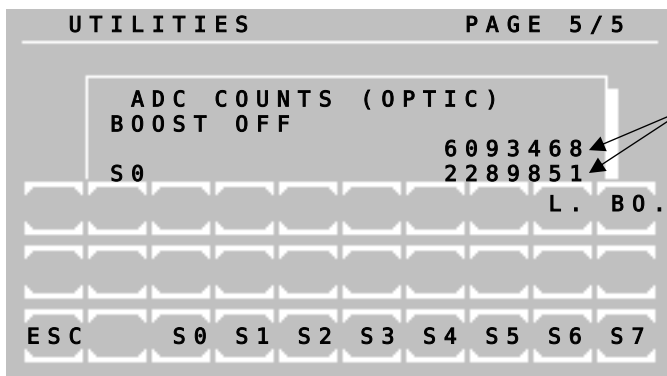

The routine assists the technician in controlling the measuring system.

Indicated are the current values of the optical analogue-digital converter (ADC). Both values are proportional to the light-current depending on special settings of the ADC.

To a key actuation the system reacts possibly with a time lag of ca. three seconds.

The function [BO.] and [S0] upto [S7] increases the sensitivity of the ADC.

The function [L.] switches the LED off and on.

Stop function by [ESC].

7.2.17 Bar Code

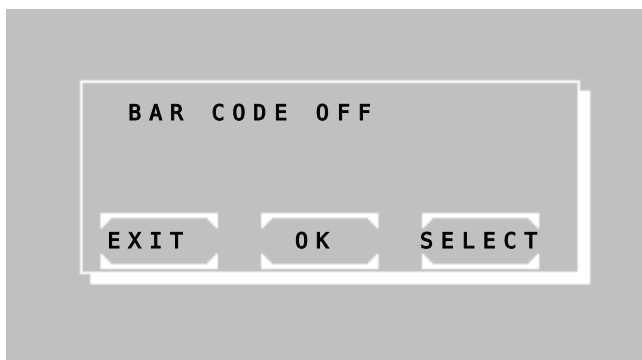

In case of using a bar code reader, results can be linked with a scanned bar code.

The setting of the RS232 interface can be changed by [SELECT].

Following options are possible:

- BAR CODE ON
Settings: Baudrate 19200 bps, 8 data bits, 1 stop bit, no parity.
- BAR CODE OFF

Save setting permanently by [OK]. The function will be switched to BAR CODE OFF in case of activating functions of chapter 7.2.5 - Menu serial COM.

Description:

A bar code like the left one can be scanned. The number of scanned characters is limited upto 15.

Alphanumerical characters are allowed.

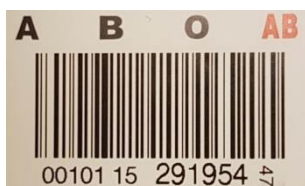

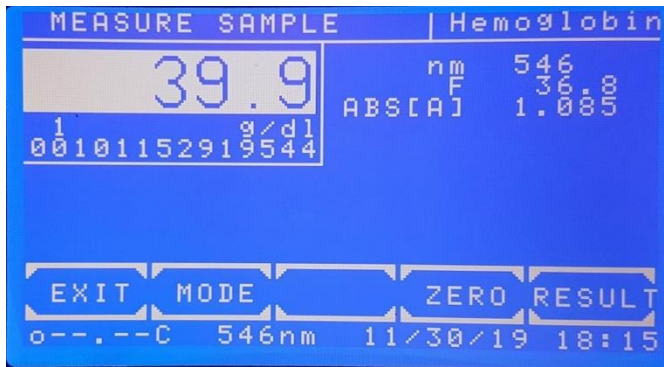

The scanned barcode will be shown before and after a measurement below the result.

The number of scanned characters is limited upto 14. 15 characters are stored in the memory.

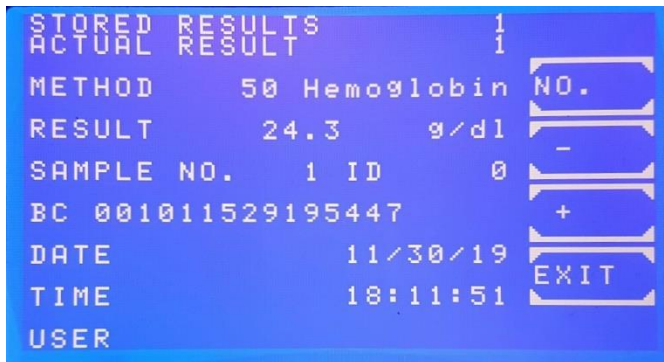

While using the function chapter 7.2.8 - Stored results the scanned barcode is shown in the line BC.

In case of not using a bar code reader but an activated function BAR CODE ON instead of a scanned bar code a generated code will be shown:

The most significant characters are representing the date:
etc. 191207 (Dec 7th, 2019)

The following characters are representing a numerator: etc. 0000001

7.2.18 Service tools

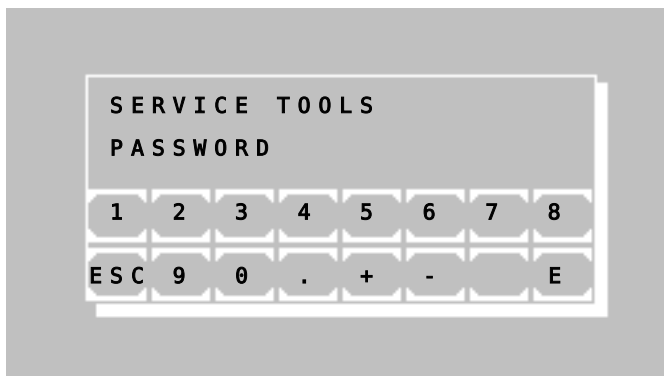

The service tools are reserved for trained specialists only and therefore protected by a password.

Stop function by [ESC].

8 MAINTENANCE

This chapter provides necessary information concerning general maintenance by the user.



If any faults should occur which cannot be remedied, then service should be contacted. Repairs at the device may be carried out only by authorized specialist staff. Through improper repairs the warranty extinguishes, and the user can be heavily jeopardized.

8.1 CLEANING INSTRUCTION



Liquid waste is potentially biologically hazardous. Always wear gloves if handling those materials. Do not touch parts of the device other than those specified. Consult the laboratory protocol for handling biohazardous materials.



Take care that no liquid enters the device! There is no protection against penetrating of liquids (Code IP X0).

For device cleaning and surface decontamination purposes use commercial decontaminating solution which are usually available in clinical chemistry laboratories like Mikrozyd® AF Liquid, Bacillo® plus, 3 % Kohrsolin® or similar solutions. Switch off the device and disconnect it from the mains voltage. Then clean the device with soft cloth and decontaminating solution.

8.2 CALIBRATING MEASURING SYSTEM

At doubtful measurement results an optic adjustment has to be carried out corresponding to chapter 7.2.1.

9 ERROR MESSAGE / CORRECTION

9.1 GENERAL NOTE

Faulty input (e.g. wrong method number or wrong factor), recognized by the user, can be corrected by filling up the respective entry field with any signs. After replenishing beyond the last position the faulty input is deleted and the entry field is free again for the renewed correct input.

Error messages by the device are carried out either exclusively via a signal tone (chapter 9.2 - ACOUSTIC ERROR MESSAGES) or as combination signal tone and display.

In the display errors are shown as plaintext (chapter 9.3 - PLAINTEXT ERROR MESSAGES)

... or coded with an error number (chapter 9.4 - CODED ERROR MESSAGES).

Each error message has always to be confirmed with [E].

9.2 ACOUSTIC ERROR MESSAGES

When pressing a key which is not permitted or not meaningful a deeper signal tone still sounds as error message after the higher signal tone (which is to confirm the keystroke, can be switched off according to chapter 7.2.12 - Key signal ON / OFF). In the display no corresponding error message appears parallel to this. The operation of the device can directly be continued by the correct keyboard entry.

9.3 PLAINTEXT ERROR MESSAGES

| | |
|------------|--|
| RANGE MIN. | The programmed low limit was under-run by the measurement. |
| RANGE MAX. | The programmed upper limit was exceeded by the measurement. |
| NO METHOD | Dialed method is not programmed. Select other method according to method list. |

9.4 CODED ERROR MESSAGES

| No. | (possible) Causes | Remedy |
|-----|---|---|
| 1 | method is write protected, method cannot be cleared | by special software |
| 2 | check sum of a freely programmed method is wrong | program new method |
| 3 | forbidden input, wrong number format | repeat input in permitted area |
| 5 | too small measurement signal (<1000 counts) | repeat optic adjustment (chapter 7.2.1); check LED / filter; check blank |
| 7 | mathematical overflow, at measurement calculation | check filter; check standard; check measuring solution |
| 8 | check sum error in the data record of the dark offset | repeat optic adjustment (chapter 7.2.1) |
| 9 | check sum error in the data record of the device basic setting (status) | automatic error remedy |
| 10 | division by a too small value (< 0.001 A) | check filter; check standard; check measuring solution |
| 11 | invalid calibration curve | Select valid number |
| 15 | no parameter memory vacant (too little memory for non-linear methods) | delete a no longer actual nonlinear method |
| 17 | check sum error in the parameter memory (nonlinear method) | program method newly |
| 20 | overflow at Kinetic | check measuring solution |
| 21 | overflow at Kinetic | check measuring solution |

| | | |
|----|---|--|
| 22 | overflow at Kinetic | check measuring solution |
| 23 | overflow at Kinetic | check measuring solution |
| 24 | overflow at Kinetic | check measuring solution |
| 25 | overflow at Kinetic | check measuring solution |
| 26 | overflow at Kinetic | check measuring solution |
| 27 | overflow at Kinetic | check measuring solution |
| 28 | overflow at Kinetic | check measuring solution |
| 29 | wrong input of deltas or time per delta | restart method |
| 30 | battery empty | contact service partner |
| 31 | communication: wrong data format | contact service partner |
| 32 | communication: sent data not plausible / not interpretable | contact service partner |
| 33 | communication: mentioned module does not answer in a certain time | check interconnecting cable; check mentioned module |
| 34 | communication: overflow send/receive buffer | reduce amount of data at the communication partner |
| 35 | remote control: wrong method number | external software problem |
| 36 | remote control: unknown command | external software problem |
| 37 | remote control: wrong data format | external software problem |
| 38 | check sum of operating system bank 0 damaged | contact service partner |
| 39 | check sum of operating system bank 1 damaged | contact service partner |
| 46 | filter position out of tolerance | contact service partner |
| 48 | time for reagent 2 is less than time for reagent 1 (CP16) | check method CP16 paramters |
| 49 | one time value in CP16 is set to zero. | check method CP16 paramters |
| 53 | set of data points is missing | check multi-standard functions |
| 55 | number of given data points < 2 | add data points |
| 62 | free method number not found | check method memory |
| 64 | current method not found in monthly memory | check QC data of method |
| 65 | more than 50 QC methods defined | delete unused QC methods |
| 66 | internal clock is off. QC data not storable | switch on internal clock |
| 67 | BCC error in dataset of QC method values | check current method |
| 68 | free monthly memory not found at QC | delete unused QC methods |
| 69 | free space in daily memory not found at QC | empty QC daily memory |
| 70 | error at QC calculation | check QC data |
| 72 | wrong address at saving test results | send results through serial interface and delete results (chapter 7.2.8) |
| 73 | results memory full, it will be overwritten | overwrite results memory or send and delete results (chapter 7.2.8) |
| 74 | BCC error at sending result string | send results through serial interface and delete results (chapter 7.2.8) |
| 87 | Concentration too high | Values outside the calibration curve |
| 88 | Concentration too low | Values outside the calibration curve |
| 90 | Error in the external text module | Reload the respective language module |

10 TECHNICAL DATA

10.1 ENVIRONMENTAL CONDITIONS

Climatic conditions for storage and transport of the packed device:

- Temperature: -25 °C to +70 °C
- Relative humidity: 20 % to 85 %
-

The Photometer 680 must be used in an environment that meets the following conditions:

- Temperature: +15 °C to +35 °C
- Relative humidity: 20 % to 85 %
- Not exposed to direct sunlight or other source of direct light (e.g. a spot light)
- Well-ventilated area
- Free from excessive dust
- Free from combustible gases
- Free from vibrations
- Free from electromagnetic wave interference
- Well-distanced from a machine generating a high frequency high voltage (e.g. a centrifuge)

10.2 MINIMAL OPERATION QUALITY



Signal processing in analogue amplifiers with high amplification factors cannot differentiate desired from undesired signals. Amplifiers thus are apt to be overloaded or produce spurious signals. The equipment will operate correctly when the undesired signals are removed. Short-term changes of the operational behavior do not influence the overall function of the device.

10.3 TYPE PLATE

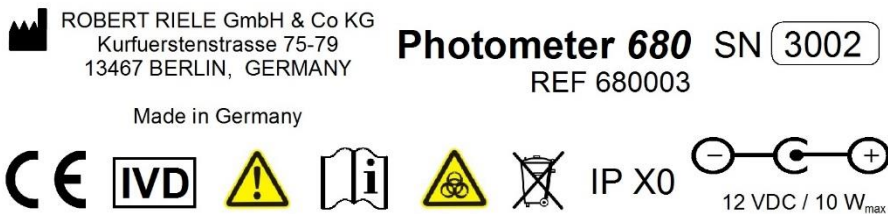
For installation pay attention to the specifications on the type plate.



10.4 SHORT SPECIFICATIONS

| | |
|-------------------------------|---|
| Type | <i>Single-beam filter photometer</i> |
| Light Source | LED with long lifetime |
| Wavelength | 340 nm and 390 nm to 800 nm |
| Wavelength Selection | <i>Interference filters in discrete holders</i> |
| Photometric Range | 0 - 3.0 A |
| Cuvette System | <i>Normal standard cuvette (macro or semi-micro, disposable or special optical glass)</i> |
| Operator Interface | <i>Touchscreen for direct functions and alphanumeric inputs</i> |
| Data Presentation | <i>Graphic display: white characters or symbols, blue background, lighted, resolution 240 * 128 dots</i> |
| Languages | <i>English and French/German/Indonesian/Russian/Spanish/Polish</i> |
| Memory | <ul style="list-style-type: none"> ▪ <i>General operating software can be updated by PC</i> ▪ <i>Reagent-open system with capacity for up to 231 programmable methods</i> ▪ <i>Data import by touchscreen or PC</i> ▪ <i>Up to 50 nonlinear calibration curves with max 20 sets of points can be stored</i> |
| Signal Port | <i>Serial port for connection to an external printer and/or PC</i> |
| Data Logging | <i>Up to 1000 results can be saved in the memory automatically</i> |
| Measurement Procedures | <ul style="list-style-type: none"> ▪ <i>Absorbance</i> ▪ <i>End point with factor, standard or multiple standards, with or without reagent blank and/or sample blank</i> ▪ <i>Turbidimetry with optional timer function</i> ▪ <i>Single, double and triple determinations</i> ▪ <i>Curve fitting for nonlinear standard curves</i> |
| Quality Control | <i>Up to 50 methods can be controlled with two control serums, Levey Jennings plot</i> |
| Power Supply | <p><i>Input: 100 V_{AC} upto 240 V_{AC} at 50/60 Hz</i></p> <p><i>Output: 12 V_{DC}, 3 A_{DC}</i></p> <p><i>Driving with 12 V_{DC} (car-)battery is possible</i></p> |
| Dimensions | <i>Length 22 cm x width 23 cm x height 8 cm</i> |
| Weight | 1.1 kg |
| Marking |   |

10.5 TECHNICAL SPECIFICATIONS**Description according to DIN 58960 part 4**

| A Identification | | |
|-------------------------|----------------------|--|
| A.1 | Type of photometer: | Photometer 680 |
| A.2 | Model: | 680 |
| A.3 | Basis-UDI-DI: | 426237161P68049 |
| A.4 | Instruction for use: | Photometer 680, user manual |
| A.5 | Manufacturer | ROBERT RIELE GmbH & Co KG Kurfuerstenstrasse 75-79 13467 Berlin Germany |

DECLARATION OF CONFORMITY:

The above mentioned absorption photometer is in conformity with the following metrological description.

Berlin, Januar 2023

ROBERT RIELE GmbH & Co KG



Dr. Linda Riele



Lorenz Riele

| B Metrological description | | |
|---|--|---|
| B.1 <u>Measuring System</u> | | |
| B.1.1 | Optical configuration: | cf. Figure |
| B.1.2 | Source[s] of radiation: | LED |
| B.1.3 | Spectroscopic apparatus: | interference filters |
| B.1.4 | Radiation detector[s]: | photodiode |
| B.1.5 | Cuvette[s]/cell[s]: | 10 mm glass or plastic cuvette (square shaped) |
| B.1.7 | Displayed units: | absorbance, mass concentration |
| B.1.8 | Display device: | digital display, absorbance: 0.000 to 3.000 mass concentration: 0.000 to 9999 |
| B.2 <u>Method of measurement</u> | | |
| B.2.1 | Generation of spectral absorbance $A(\lambda)$ | monochromatic measurement |
| B.2.2 | Zero compensation of spectral absorbance | manual |
| B.2.3 | Control of the measured spectral absorbance: | with an absorption reference solution (see manual) |
| B.2.4 | Determination[s] of concentration: | Lambert-Beer-Equation |

B.3 Specified measuring range

Outside the specified measuring range and under rated operating conditions other than those stated in section B.4, the maximum permissible errors given in section B.5 can be exceeded.

| | | |
|-------|--|-----------------------------|
| B.3.1 | Spectral absorbance $A(\lambda)$: | 0 A to 3.0 A |
| B.3.2 | Wavelength λ useable for measurements: | 340 nm and 390 nm to 800 nm |

B.4 Specified Operation conditions

| | | |
|-------|--|---|
| B.4.1 | Spectral transmittance of the cuvette: | > 75 % |
| B.4.2 | Warm-up time: | 15 min |
| B.4.3 | Operating voltage [mains]: | between 100 V _{AC} and 240 V _{AC} at 50/60 Hz with a tolerance of 10 % |
| B.4.4 | Ambient temperature: | 15 °C to 35 °C |
| B.4.5 | Sound pressure level SPL | < 30 dB |

B.5 Maximum permissible errors and other limiting values

| | | |
|-------|---|--|
| B.5.1 | Photometric uncertainty of the spectral absorbance: | $0.2 < A \leq 0.5 \rightarrow \pm 10$ digit $A > 0.5 \rightarrow \pm 3$ % |
| B.5.2 | Photometric short-time variation coefficient: | ≤ 1 % |
| B.5.3 | Uncertainty of wavelengths: | max ± 2 nm |
| B.5.4 | Spectral half-width of spectral radiation flux at detector: | ≤ 10 nm |
| B.5.5 | Percentage of wavelength integrated false radiation (measured at 340 nm as transmittance of a cut-off filter NaNO ₃): | ≤ 0.1 % |

OPTIC CONSTRUCTION

The path of rays is directed from the right to the left of the device. Insert standard cuvette accordingly.

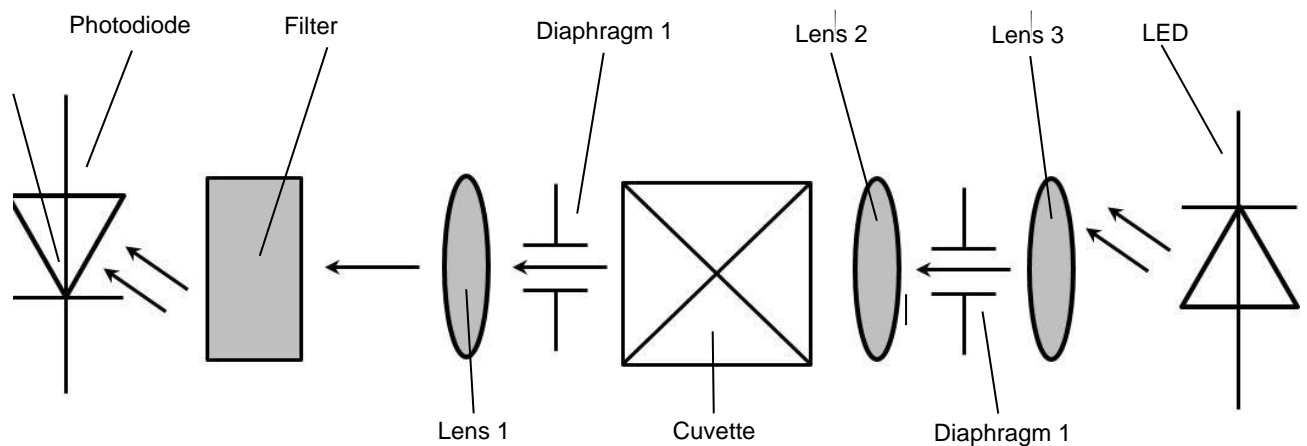

11 ACCESSORIES AND SPARE PARTS

Kindly contact directly the responsible dealer.

| REF | Description |
|------------|---|
| 600-340 | Interference filter 340 nm |
| 600-405 | Interference filter 405 nm |
| 600-436 | Interference filter 436 nm |
| 600-492 | Interference filter 492 nm |
| 600-546 | Interference filter 546 nm |
| 600-578 | Interference filter 578 nm |
| 600-623 | Interference filter 623 nm |
| 600-670 | Interference filter 670 nm other wavelengths on request |
| 805-410 | Cuvettes, 10 mm layer thickness: Disposable cuvettes, 1000 pcs |
| 0573655001 | Cuvettes of optical glass, 4 pcs |
| 500-002 | Incubator T12 |
| 500-005 | Incubator T20 |
| 090-064 | Secondary calibration standards, four-piece, certified |
| 501-002 | Data cable serial interface |



Incubator T12



Incubator T20

12 METHOD LIST

1 - 14.....12 basic methods (chapter 12.1 - BASIC METHOD)

20 - 250.....up to 231 user specific methods (chapter 12.2 - LIST OF USER SPECIFIC METHODS as copy master / to be filled out by the user)

12.1 BASIC METHODS

| No. | Method Name | Dim | CP | Characteristic | λ [nm] | Factor Standard | Delay Incubation [s] | Reaction [s] | Min. Units | Max. Units |
|-----|-------------|-----|----|----------------|-------------------|--------------------|----------------------------|-----------------|------------|------------|
| 1 | C/F | | 1 | C/F | | | | | | |
| 2 | C/F/Rb | | 2 | C/F/Rb | | | | | | |
| 3 | C/F/Sb | | 3 | C/F/Sb | | | | | | |
| 4 | C/F/SbRb | | 4 | C/F/SbRb | | | | | | |
| 5 | C/S | | 5 | C/S | | | | | | |
| 6 | C/S/Rb | | 6 | C/S/Rb | | | | | | |
| 7 | C/S/Sb | | 7 | C/S/Sb | | | | | | |
| 8 | C/S/SbRb | | 8 | C/S/SbRb | | | | | | |
| 9 | FTK/F/Rb | | 9 | FTK/F/Rb | | | | | | |
| 10 | FTK/S/Rb | | 10 | FTK/S/Rb | | | | | | |
| 13 | TRANSM. | % | 13 | TRANSM. | | | | | | |
| 14 | C / F delta | | 14 | C / F delta | | | | | | |

12.2 LIST OF USER SPECIFIC METHODS

| No. | Method Name | Dim | CP | Characteristic | λ [nm] | Factor Standard | Delay Incubation [s] | Reaction [s] | Min. Units | Max. Units |
|-----|-------------|-----|----|----------------|----------------|-----------------|----------------------|--------------|------------|------------|
| | | | | | | | | | | |
| | | | | | | | | | | |
| | | | | | | | | | | |
| | | | | | | | | | | |
| | | | | | | | | | | |
| | | | | | | | | | | |
| | | | | | | | | | | |
| | | | | | | | | | | |
| | | | | | | | | | | |
| | | | | | | | | | | |
| | | | | | | | | | | |
| | | | | | | | | | | |
| | | | | | | | | | | |
| | | | | | | | | | | |
| | | | | | | | | | | |
| | | | | | | | | | | |
| | | | | | | | | | | |
| | | | | | | | | | | |
| | | | | | | | | | | |
| | | | | | | | | | | |
| | | | | | | | | | | |
| | | | | | | | | | | |